

Xenotech, Inc.[®]

BRITELIGHT[®]

**10000AR X2
INSTALLATION MANUAL**

REV 2.0b

COPYRIGHT © 1997 Xenotech, Inc.

BRITELIGHT 10000AR SPECIFICATIONS

POWER SUPPLY

MAIN POWER INPUT

INPUT VOLTAGE: 380 VAC.
INPUT CURRENT: 20 AMPS
PHASE: THREE
FREQUENCY: 60/50 HZ.

CONTROL INPUT

SWITCH CLOSURE
NORMALLY OPEN 5 AMP 120 VAC CONTACT RATING

OUTPUT

OUTPUT VOLTAGE: 50 - 60 VDC.
OUTPUT CURRENT: 190 - 220 ADC.
OUTPUT RIPPLE: LESS THAN 5% P-P
OUTPUT ADJ. RANGE: 16 STEPS

LAMP HEAD

LAMP INPUT

LAMP VOLTAGE: 50 - 60 VDC.
LAMP CURRENT: 190 - 200 ADC.

COOLING & IGNITION CIRCUIT INPUT

INPUT VOLTAGE: 120 VAC.
INPUT CURRENT: 5 AMPS PEAK
PHASE: SINGLE
FREQUENCY: 60 HZ.

SYSTEM OPERATION TEMPERATURE RANGE

NOMINAL AMBIENT: 0° - 50° C.

SYSTEM WEIGHT

900 LBS.

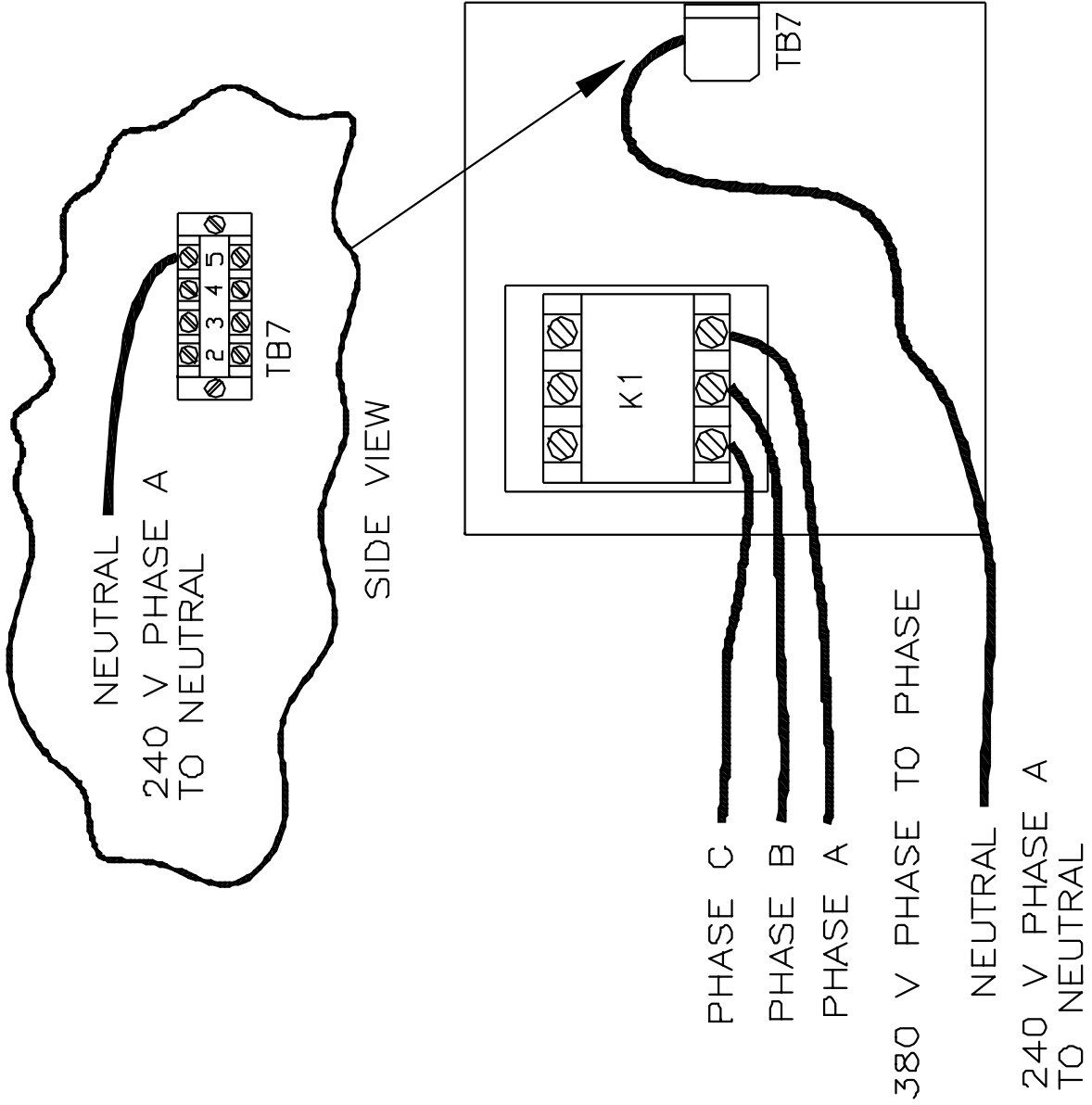

LAMP HEAD HOOKUP @ BALLAST OUTPUT

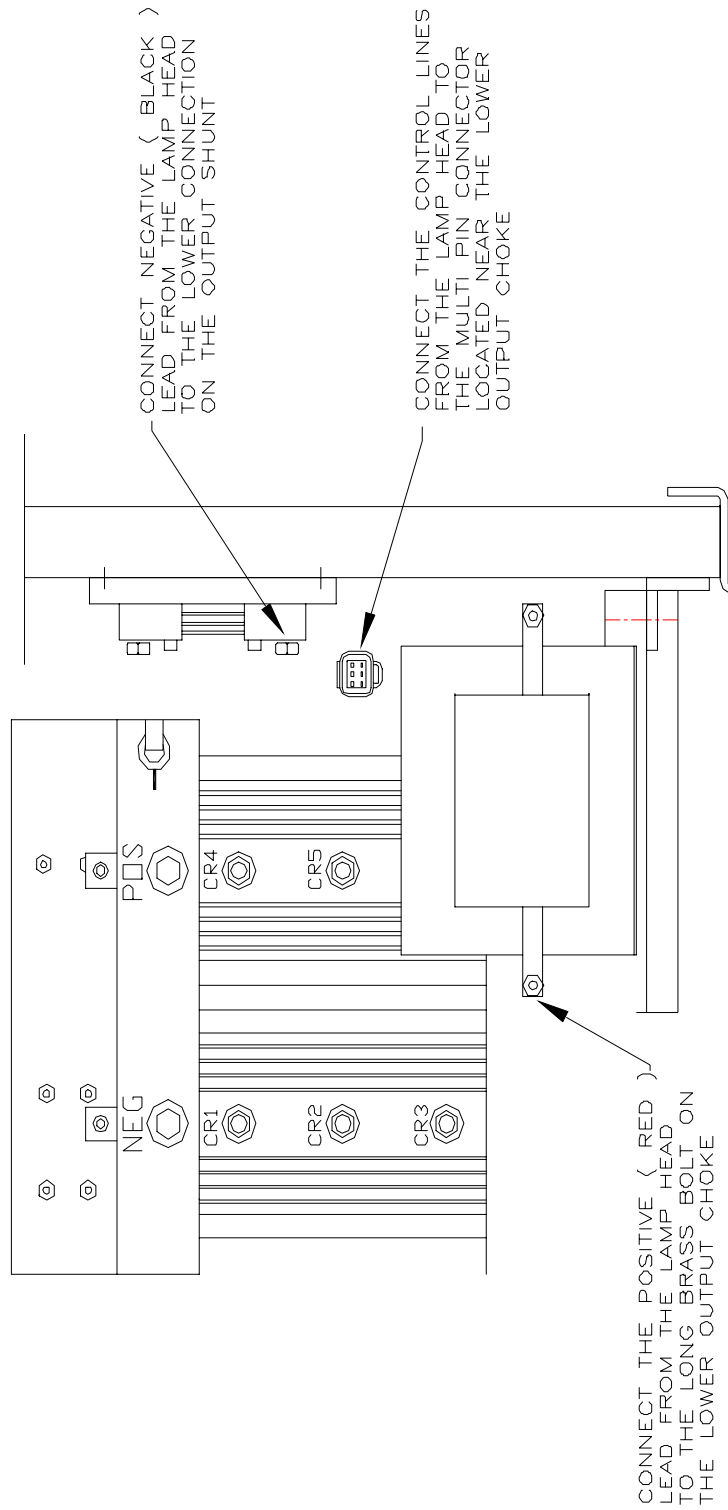

CONNECT THE POSITIVE (RED) LEAD FROM THE LAMP HEAD TO THE LONG BRASS BOLT ON THE LOWER OUTPUT CHOKE

NOTE: REMOVE FIRST NUT AND WASHERS ONLY.

REMOTE CONTROL HOOKUP
 AT CONTROL PCB
 AT FRONT UPPER POWER SUPPLY

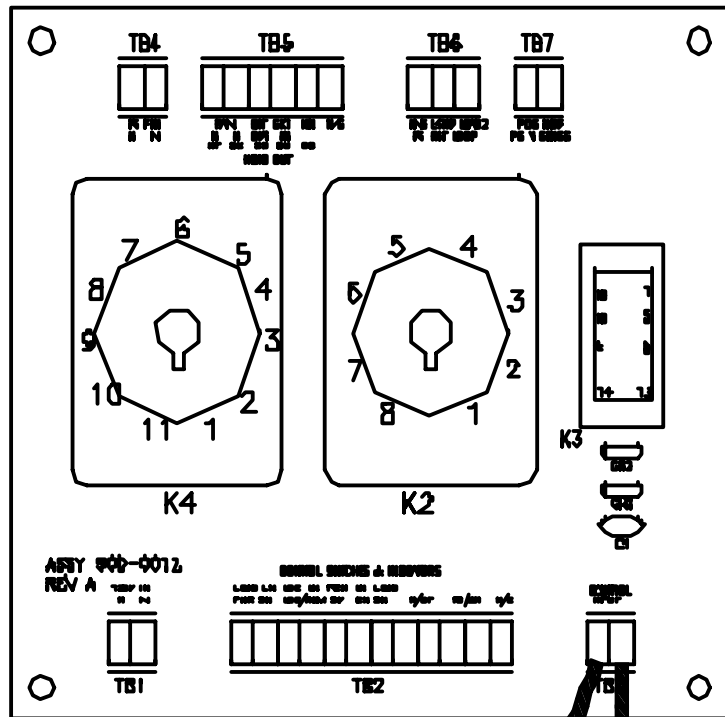

REMOTE CONTROL
 INPUT
 SWITCH CLOSURE
 120 VAC 2 AMP
 SUPPLIED BY
 PCB

BRITELIGHT 10000ARX2 INSTALLATION INSTRUCTIONS

NOTE

THE BL10000ARX2 SYSTEM SHOULD BE INSTALLED BY AN ELECTRICAL CONTRACTOR FOLLOWING ALL APPLICABLE ELECTRICAL AND BUILDING CODES FOR THE INSTALLATION SITE.

UNPACKING

BASE UNIT

1. Remove the system base from its shipping pallet by removing the 4 retaining bolts from the base footings and lifting the system from the pallet.
2. Position the system base in the location that it will be operating and check the system for stability. It is recommended that the system be bolted down to the mounting surface. If the surface is uneven it may be necessary to shim the footings of the base unit to stabilize the system.
3. When positioning the system be sure to allow adequate clearance for the air intakes and exhausts on both the base and head units and also adequate clearance to the front and back of the base unit for service and for a full range of motion of the lamp head.

LAMP HEAD

1. Unpack the lamp head by unwrapping it and cutting the banding straps.
2. Remove two adjacent lamp head retaining clamps from the top of the base and loosen the two remaining clamps in preparation for mounting the lamp head.
3. Lift the lamp head from the pallet and position the support plate under the two mounting clamps on the top of the base. Point the lamp head in the desired operating direction and install the remaining

clamps.

CONNECTIONS

LAMP HEAD

1. Remove the front and rear base covers. Examine the interior of the base for any hidden damage, loose connections, missing components, or other damage and changes that may have occurred during shipping.
2. Locate the cord grip assembly at the end of the lamp head cable and remove the locknut from the cord grip.
3. Insert the lamp head cable end through the hole located on the lower right side of the base until the cord grip is fully seated. Reinstall the locknut on the cord grip and tighten until the cord grip is secure.

CAUTION

EXTREME CARE MUST BE TAKEN WHEN CONNECTING THE LAMP HEAD TO THE BALLAST OUTPUT IF THE POLARITY OF THE CONNECTIONS ARE REVERSED THE XENON GLOBE WILL BE IMMEDIATELY DESTROYED UPON IGNITION.

NOTE

ONLY LOOSEN THE FIRST NUT ON THE LOWER OUTPUT CHOKE TERMINAL WHEN CONNECTING THE LAMP HEAD

4. Connect the large red wire from the lamp head cable to the long brass stud located on the lower output choke.
5. Connect the large black wire to the lower connecting bolt on the output shunt located above and to the right of the lower output choke.
6. Locate the multi-pin connector in the general location of the lower output choke and the output shunt connections. Connect the mating control wire connector from the lamp head cable to this connector. When the connectors are properly mated they will lock into position.
8. Check the routing of the lamp head wiring and tightness of the high current connections. The lamp head installation is now complete.

POWER AND CONTROL

1. The BL10000ARX2 system requires one electrical service and one external remote switch closure to operate as designed. The main power service should be a 380/230 volt 3 phase minimum 20 amp service that is always energized. The remote control circuit should be a normally open switch closure rated at 5 amps 120 vac that is controlled by a timer or other control system to turn the system on and off at the required times.
2. To allow flexibility in the installation of the BL10000ARX2 system no pre knocked out holes have been provided. Instead appropriate holes can be punched at any convenient location in the left and right side panels during installation as allowed by local codes.
3. The main power input and remote control wiring connections for the BL10000ARX2 are very straight forward and are shown on the installation wiring drawing. Remove the front and rear access panels on the base unit to install the power service. Connect the hot lines from the main power service to the line side (bottom) of contactor K1 located on the lower power supply. The neutral line connects to terminal board TB7 terminal #5 located next to the contactor. The remote control power wiring is connected to terminal block TB3 located on the control PCB in front of the upper power supply. All input grounds attach to the ground stud located at the lower left of the heatsink assembly on the lower power supply.
4. The main power and control installation is now complete. Proceed to the globe installation procedures.

BL10000ARX2 CONTROL PANEL & SYSTEM OPERATION

1. MAIN POWER SWITCH

Used to manually control the system operation. When the normal / service selector switch is in the normal position the main power switch will prevent the system from energizing when the control power circuit turns on. When the normal / service selector switch is in the service position the main power switch acts as a normal power switch turning the system both on and off.

2. NORMAL / SERVICE SELECTOR SWITCH

Used to select the mode of operation for the system. When this switch is in the normal position the system is energized and de-energized by the remote control circuit. When this switch is in the service position the system generates it's control power internally from the 230 volt main service so the system can be operated as an independent unit without the remote control circuit energized.

3. CIRCUIT BREAKER CB2

This circuit breaker protects the remote control power circuit output and the 120vac auxiliary power source from overloads and short circuits.

4. MANUAL STRIKE SWITCH

This switch is not normally used. It has been installed as a trouble shooting aid. This switch is wired in parallel with the auto strike relay circuit. If a system does not strike automatically this switch will energize the ignitor circuit in the lamp head. If the ignitor in the head fires when this switch is depressed the ignitor circuit in the head is in operating order. If the ignitor works and the lamp lights then the auto strike circuit should be checked. If the lamp does not light when the ignitor fires then the trouble may be in the power supply or lamp head.

5. PHASE FAULT CIRCUIT INTERRUPTER CB1

If the 380 volt main power service loses a phase while the system is running or a component in the power supply fails causing excessive output ripple this device will trip disabling the system operation. This device will not self reset. It will be necessary to locate the cause of the trouble correct the problem and then reset CB1 located on the left power supply panel on both power supplies inside the base.

LAMP HEAD

1. FOCUS SWITCH

Located on the rear of the lamp head this switch is used to focus the searchlights beam angle. Moving the switch to the upper or lower position starts the motor that adjusts the lamp. Moving the switch to the opposite position reverses the movement.

NOTE

THE TWO PUSH BUTTON SWITCHES TO THE RIGHT OF THE FOCUS SWITCH ARE REMOTE LAMP STRIKE AND OFF SWITCHES AND ARE NOT USED ON SYSTEMS ARCHITECTURAL SYSTEMS INCORPORATING AUTOMATIC IGNITION CIRCUITRY. PRESSING THE OFF SWITCH WHILE THE LAMP IS LIT WILL CAUSE THE LIGHT TO EXTINGUISH MOMENTARILY UNTIL THE AUTO IGNITION RESTARTS THE LAMP. PRESSING THE ON BUTTON WILL ENERGIZE THE IGNITOR CIRCUIT. THIS FUNCTION IS THE SAME AS THE MANUAL STRIKE SWITCH LOCATED ON THE BALLAST CONTROL PANEL AND MAY BE USED TO TEST A SYSTEM THAT DOES NOT AUTOSTRIKE.

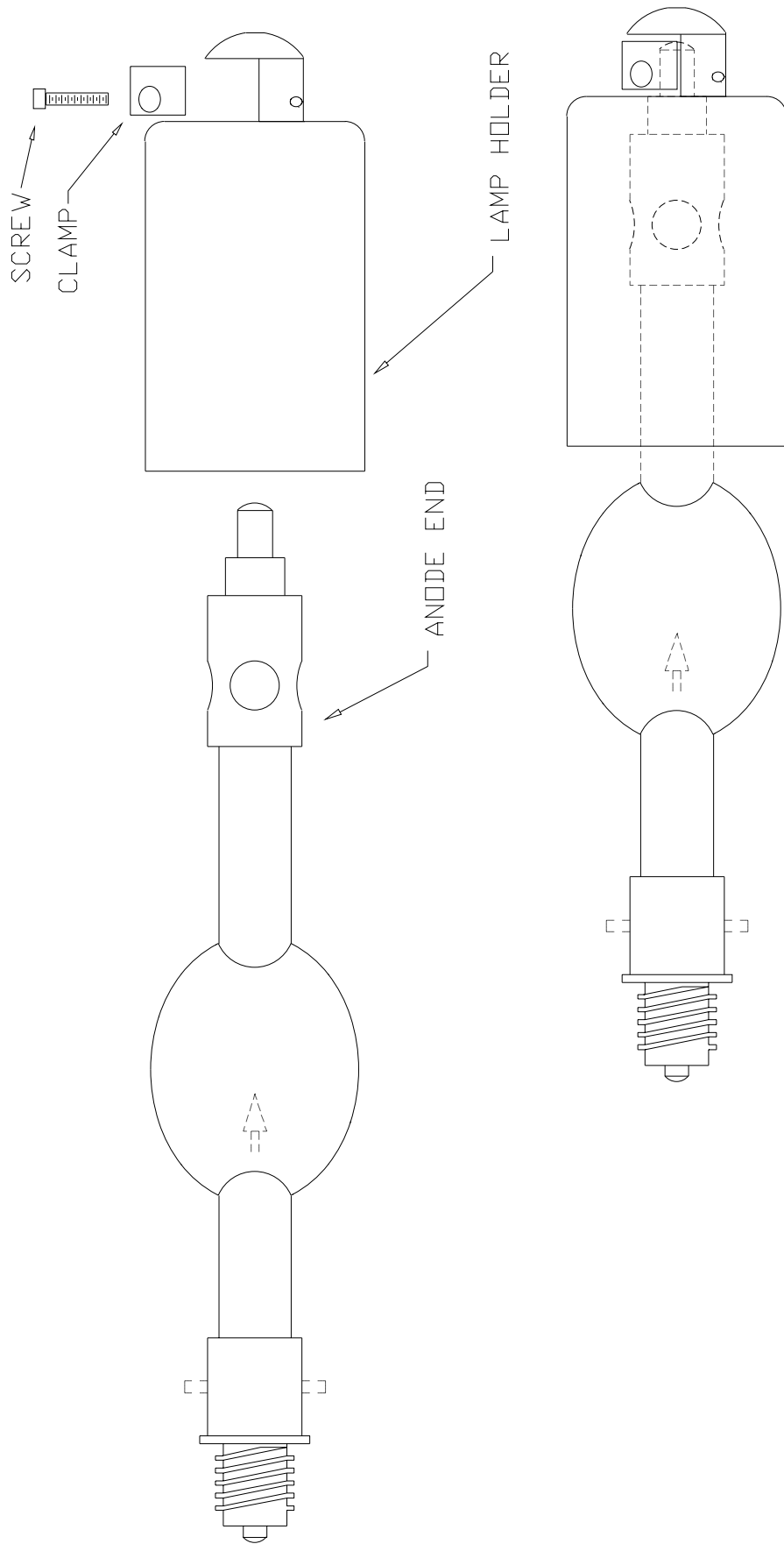

FRONT LAMP HOLDER ASSEMBLY

INSTRUCTIONS FOR REMOVING AND INSTALLING A TYPE TH LAMP IN A SUPER 10 FIXTURE

NOTE

FAMILIARIZE YOURSELF WITH THE LOCATION AND IDENTIFICATION OF THE COMPONENTS OF THIS SYSTEM AND ALSO THE NORMAL OPERATION OF THE SYSTEM BEFORE ATTEMPTING ANY ADJUSTMENT OR SERVICE.

NOTE

COMPLETELY READ THROUGH AND HAVE A GOOD UNDERSTANDING OF THE PROCEDURES BEFORE ATTEMPTING TO SERVICE THIS SYSTEM. FAILURE TO DO SO MAY RESULT IN FATAL INJURY OR EQUIPMENT DAMAGE.

NOTE

THE LAMP HEAD SHOULD BE IN THE HORIZONTAL POSITION DURING THE GLOBING PROCEDURES.

WARNING

DISCONNECT POWER SOURCE BEFORE SERVICING THIS EQUIPMENT.

WARNING

A PROTECTIVE JACKET, FULL FACE SHIELD, AND PROTECTIVE GLOVES MUST BE WORN AT ALL TIMES WHEN THE LAMP HEAD IS OPENED WITH A LAMP INSTALLED OR WHEN HANDLING THE XENON LAMPS. SERIOUS INJURY MAY OCCUR IF PROPER SAFETY PRECAUTIONS ARE NOT OBSERVED. READ ALL ENCLOSED INSTRUCTIONS AND INFORMATION SHEETS BEFORE HANDLING THE LAMP.

WARNING

NEVER OPERATE A FIXTURE WITH AN EXPOSED LAMP! THERE IS AN EXTREME DANGER OF SEVERE BURNS TO EXPOSED SKIN AND EYES FROM THE ULTRAVIOLET LIGHT EMITTED FROM THE EXPOSED LAMP. DAMAGE CAN OCCUR IN AS LITTLE AS 30 SECONDS OF EXPOSURE. THERE IS ALSO AN ADDITIONAL DANGER FROM FLYING GLASS IF AN EXPOSED LAMP EXPLODES!

EQUIPMENT REQUIRED

1. PROTECTIVE SAFETY EQUIPMENT KIT
2. 7/16 WRENCH OR SOCKET
3. ALLEN WRENCH 5/32

DISASSEMBLY PROCEDURE

IF THERE IS NO LAMP INSTALLED IN THE FIXTURE

1. RELEASE THE 4 FASTENERS LOCATED AT THE SMALL SIDES OF THE COWL BY PRESSING IN ON THE FASTENERS AND PULLING FORWARD TO REMOVE THE COWLING.
2. REMOVE THE 2 BRASS BOLTS CONNECTING THE SHORT LEADS TO THE FRONT LAMP HOLDER USING A 7/16 WRENCH.
3. REMOVE THE CENTER MOUNTING SCREW WASHER AND SPRING FROM THE SPIDER USING A 5/32 ALLEN WRENCH WHILE SUPPORTING THE FRONT LAMP HOLDER SO THAT IT DOES NOT FALL WHEN THE SCREW IS REMOVED.
4. REMOVE THE LAMP HOLDER FROM THE FIXTURE.
5. TO DISASSEMBLE THE FRONT LAMP HOLDER REMOVE THE 2 CLAMP RETAINING SCREWS LOCATED ON THE SIDE OF THE LAMP SWIVEL HUB USING A 5/32 ALLEN WRENCH AND REMOVE THE CLAMP.

DISASSEMBLY PROCEDURE

IF THERE IS A LAMP IS INSTALLED IN THE FIXTURE

1. RELEASE THE 4 FASTENERS LOCATED AT THE SMALL SIDES OF THE COWL BY PRESSING IN ON THE FASTENERS AND PULLING FORWARD TO REMOVE THE COWLING.

CAUTION

DO NOT PLACE ANY EXCESSIVE FORCE ON THE LAMP WHILE REPLACING THE PROTECTIVE WRAPPER!

2. WRAP THE LAMP SECURELY IN THE PROTECTIVE WRAPPER THAT THE LAMP WAS ORIGINALLY SHIPPED WITH.
3. REMOVE THE 2 BRASS BOLTS CONNECTING THE SHORT LEADS TO THE FRONT LAMP HOLDER USING A 7/16 WRENCH.
4. REMOVE THE CENTER MOUNTING SCREW WASHER AND SPRING FROM THE SPIDER USING A 5/32 ALLEN WRENCH WHILE SUPPORTING THE FRONT LAMP HOLDER SO THAT THE LAMP DOES NOT DROP WHEN THE MOUNTING SCREW IS REMOVED.

WARNING

DO NOT EXSERT EXCESSIVE FORCE ON THE LAMP WHILE UNSCREWING IT FROM THE REAR LAMP HOLDER! THE LAMP SHOULD RELEASE FROM THE REAR LAMP HOLDER WITH A VERY LIGHT COUNTER CLOCKWISE ROTATION IF THIS DOES NOT HAPPEN SEE THE PROCEDURE FOR REMOVING A FROZEN LAMP.

5. REMOVE THE LAMP BY LIGHTLY PUSHING BACK ON THE LAMP TO MOVE THE REAR LAMP HOLDER TO IT'S REAR MOST POSITION WHILE LIGHTLY TURNING THE LAMP IN A COUNTERCLOCKWISE ROTATION. THE LAMP WILL RELEASE FROM THE REAR LAMP HOLDER IN APPROXIMATELY 1.5 COMPLETE TURNS.
6. REMOVE THE LAMP WITH THE FRONT LAMP HOLDER ATTACHED FROM THE FIXTURE AND PLACE IT ON A STABLE WORKING SURFACE FOR THE REMOVAL OF THE FRONT LAMP HOLDER.
7. TO REMOVE THE FRONT LAMP HOLDER FROM THE LAMP REMOVE THE 2 CLAMP RETAINING SCREWS LOCATED ON THE SIDE OF THE LAMP SWIVEL HUB USING A 5/32 ALLEN WRENCH AND REMOVE THE CLAMP.
9. REMOVE THE LAMP HOLDER FROM THE LAMP AND PLACE THE LAMP INTO ITS SHIPPING CONTAINER FOR

SAFE KEEPING. RESECURE THE PROTECTIVE WRAPPER IF NECESSARY.

REMOVING A FROZEN LAMP

1. REPLACE THE FRONT LAMP HOLDER RETAINING BOLT TO SUPPORT THE FRONT OF THE LAMP WHILE FREEING THE LAMP FROM THE REAR LAMP HOLDER.

WARNING

DO EXERT ANY FORCE ON THE GLASS PORTIONS OF THE LAMP WHILE ATTEMPTING TO FREE IT FROM THE REAR LAMP HOLDER!

2. REACH THROUGH THE OPENING IN THE REAR OF THE REFLECTOR AND GRASP THE LAMP BY ITS REAR FERRULE AND WHILE LIGHTLY PUSHING THE LAMP BACK INTO THE RECEIVER BLOCK TURN THE LAMP IN A COUNTERCLOCKWISE DIRECTION UNTIL THE LAMP BEGINS TO ROTATE FREELY.
3. ONCE THE LAMP IS FREE DO NOT REMOVE IT COMPLETELY FROM THE REAR LAMP HOLDER.
4. RETURN TO STEP 5 OF :

“DISASSEMBLY PROCEDURE

IF THERE IS A LAMP IS INSTALLED IN THE FIXTURE”

ASSEMBLY PROCEDURE

WARNING

DO NOT REMOVE THE PROTECTIVE COVER FROM THE LAMP UNTIL INSTRUCTED TO DO SO!

WARNING

DO EXERT ANY FORCE ON THE GLASS PORTIONS OF THE LAMP AT ANY TIME!

NOTE

IF THE FRONT LAMP HOLDER HAS NOT BEEN DISASSEMBLED SEE THE LAST STEPS IN THE APPROPRIATE DISASSEMBLY INSTRUCTIONS.

1. UNTIE THE CORD ON THE ANODE END OF THE PROTECTIVE COVER. DO NOT REMOVE THE COVER AT THIS TIME!
2. FASTEN FRONT LAMP HOLDER TO THE LAMP BY PLACING THE ANODE END (LARGE ELECTRODE) OF THE LAMP IN THE LAMP HOLDER AND ALIGNING THE STUD ON THE END OF THE LAMP FERRULE WITH THE CHANNEL IN THE NOSE OF THE LAMP HOLDER BODY. SLIDE THE LAMP COMPLETELY DOWN THE CHANNEL AS FAR AS IT WILL GO.

WARNING

DO NOT PLACE ANY PRESSURE ON THE LAMP WHILE REASSEMBLING THE FRONT LAMP HOLDER!

3. REPLACE THE CLAMP AND REINSTALL THE 2 CLAMP RETAINING SCREWS LOCATED ON THE SIDE OF THE LAMP SWIVEL HUB USING A 5/32 ALLEN WRENCH.
5. INSTALL THE LAMP INTO THE FIXTURE BY INSERTING THE CATHODE END OF THE LAMP THROUGH THE OPENING IN THE REFLECTOR.
6. INSERT THE END OF THE LAMP FERRULE INTO THE OPENING IN THE REAR LAMP HOLDER RECEIVER BLOCK AND ALIGN THE THREADS BY TURNING THE LAMP COUNTERCLOCKWISE UNTIL THE LAMP THREADS DROP INTO THE RECEIVER THREADS.

CAUTION

DO NOT OVER TIGHTEN THE LAMP IN THE RECEIVER BLOCK AS THIS MAY CAUSE THE LAMP TO FREEZE IN THE RECEIVER BLOCK MAKING IT DIFFICULT TO REMOVE. TIGHTEN THE LAMP JUST ENOUGH TO APPLY SPRING PRESSURE TO THE THREADS BUT NOT SO MUCH AS TO BOTTOM OUT THE LAMP FERRULE COMPLETELY AGAINST THE RECEIVER BLOCK.

7. GENTLY ROTATE THE LAMP CLOCKWISE UNTIL RESISTANCE IS FELT.
8. AT THIS POINT THE LAMP SHOULD BE IN CONTACT WITH THE SPRING PLUNGER ASSEMBLIES. GENTLY TURN THE LAMP AN ADDITIONAL 1/16-1/8 OF A TURN TO LOAD THE THREADS WITH THE SPRING PLUNGERS.
9. SECURE THE FRONT LAMP HOLDER TO THE SPIDER WITH THE SHOULDER BOLT, SPRING, AND WASHER THAT WAS REMOVED DURING DISASSEMBLY.
10. CONNECT THE 2 SHORT LEADS FROM THE SPIDER TO THE FRONT LAMP HOLDER USING THE 2 BRASS BOLTS AND WASHERS THAT WERE REMOVED DURING DISASSEMBLY.

NOTE

ANY TYPE OF ALCOHOL IS SUITABLE FOR CLEANING THE LAMP EXCEPT FOR ALCOHOL THAT HAS BEEN

DENATURED USING PETROLEUM PRODUCTS SINCE THE DENATURING AGENT WILL LEAVE A RESIDUE ON THE LAMP.

11. REMOVE THE PROTECTIVE COVER FROM THE LAMP AND CLEAN THE GLASS PORTION OF THE LAMP COMPLETELY WITH ALCOHOL.
12. THE INSTALLATION IS NOW COMPLETE. REPLACE THE FRONT COWL AND TEST THE LAMP.
13. LOG THE HOUR METER READING AT INSTALLATION.
14. PERFORM THE OUTPUT POWER ADJUSTMENT PROCEDURES.
15. PREFORM THE FOCUS AND X-Y PROCEDURES.

FOCUS AND X-Y ADJUSTMENT INSTRUCTIONS FOR SYSTEMS W/ ELECTRIC FOCUS

NOTE

FAMILIARIZE YOURSELF WITH THE LOCATION AND IDENTIFICATION OF THE COMPONENTS OF THIS SYSTEM AND ALSO THE NORMAL OPERATION OF THE SYSTEM BEFORE ATTEMPTING ANY ADJUSTMENT OR SERVICE.

NOTE

COMPLETELY READ THROUGH AND HAVE A GOOD UNDERSTANDING OF THE PROCEDURES BEFORE ATTEMPTING TO SERVICE THIS SYSTEM. FAILURE TO DO SO MAY RESULT IN FATAL INJURY OR EQUIPMENT DAMAGE.

EQUIPMENT REQUIRED

1. ALLEN WRENCH 5/32
2. # 5 WELDERS GLASSES OR VERY DARK SUNGLASSES

WARNING

THE SUPER 10 SYSTEMS PROJECT A VERY INTENSE BEAM OF FULL SPECTRUM LIGHT. THE USE OF DARK GLASSES WHILE ADJUSTING THE BEAM PARAMETERS ON A LIGHT COLORED REFLECTIVE SURFACE AT A CLOSE DISTANCE IS REQUIRED.

WARNING

NEVER LOOK DIRECTLY INTO A LIT FIXTURE'S LIGHT SOURCE.

ADJUSTMENT INSTRUCTIONS

1. LOOSEN THE POSITIONING FASTENERS AND POINT THE LAMP HEAD TOWARD A WALL, CEILING, OR OTHER FLAT SURFACE AT LEAST 10 FEET AWAY.
2. LOCATE THE FOCUS SWITCH LOCATED ON THE REAR OF THE LAMP HEAD.
3. REMOVE THE FRONT COWL AND LOCATE THE X & Y ADJUSTMENT HOLES LOCATED ON THE LOWER SMALL SIDES OF THE FIXTURE AT THE ENDS OF THE FRONT SPIDER ARMS.

WARNING

THE SUPER 10 SYSTEMS PROJECT A VERY INTENSE BEAM OF FULL SPECTRUM LIGHT. CAUTION MUST BE TAKEN WHEN POINTING THE BEAM AT AN OBJECT AT A DISTANCE OF LESS THAN 100 FEET WITH THE FOCUS SET FOR A CONVERGING BEAM. COMBUSTIBLE OBJECTS AND OBJECTS WITH A DARK COLOR MAY UNEXPECTEDLY IGNITE IF CARE IS NOT TAKEN IN THE FOCUSING AND POSITIONING OF THE BEAM.

4. ENERGIZE THE FIXTURE AND IGNITE THE LAMP.
5. ADJUST THE FOCUS BY MOVING THE FOCUS SWITCH UP OR DOWN TO PRODUCE A DIVERGING BEAM PATTERN WITH 2-3 CLEARLY DEFINED RINGS OF LIGHT WITH OR WITHOUT AN OFF CENTER HOT SPOT.
6. ADJUST THE X & Y ADJUSTMENT SCREWS USING A 5/32 ALLEN WRENCH TO MOVE THE INNER RINGS OF LIGHT TO CREATE CONCENTRIC RINGS WITH THE HOT SPOT AT THE CENTER OF THE LIGHT FIELD. TURNING THE ADJUSTMENT SCREW CLOCKWISE WILL MOVE THE RINGS TOWARD THAT ADJUSTMENT AXIS AND TURNING THE SCREW COUNTERCLOCKWISE WILL MOVE THE RINGS AWAY FROM THAT ADJUSTMENT AXIS.
7. READJUST THE FOCUS SCREW TO SET THE DESIRED BEAM SPREAD.
8. REPLACE THE FRONT COWL REPOSITION THE LAMP HEAD AND RESECURE THE POSITION LOCKING FASTENERS.

OUTPUT POWER ADJUSTMENT PROCEDURES

NOTE

FAMILIARIZE YOURSELF WITH THE LOCATION AND IDENTIFICATION OF THE COMPONENTS OF THIS SYSTEM AND ALSO THE NORMAL OPERATION OF THE SYSTEM BEFORE ATTEMPTING ANY ADJUSTMENT OR SERVICE.

NOTE

COMPLETELY READ THROUGH AND HAVE A GOOD UNDERSTANDING OF THE PROCEDURES BEFORE ATTEMPTING TO SERVICE THIS SYSTEM. FAILURE TO DO SO MAY RESULT IN FATAL INJURY OR EQUIPMENT DAMAGE.

WARNING

DISCONNECT POWER SOURCE BEFORE SERVICING THIS EQUIPMENT.

WARNING

THIS SYSTEM MAY BE UNDER THE CONTROL OF AN AUTOMATIC TIMING SYSTEM AND MAY START AT ANY TIME WHEN THE NORMAL / SERVICE SELECTOR SWITCH IS IN THE NORMAL POSITION.

EQUIPMENT REQUIRED

1. SCREWDRIVER FLAT BLADE, LARGE
2. WRENCH 3/8

ADJUSTMENT INSTRUCTIONS

1. Remove lower access cover from the rear of the base enclosure by removing the 6 screws along the sides of the panel with a 3/8 wrench.
2. Note the location and settings of the power supply adjustment taps.
3. If the system is to be adjusted without the control timing circuit energized set the main power switch to the off position and set the normal / service selector switch to the service position.
4. Set the main power switch to the on position. The unit cooling system should start immediately, and the lamp should strike after a several second delay. If nothing happens and the selector switch is set per step 3 check the main 3 phase power supplying this system in all likelihood the main power has been turned off at the source. If the system has power the output setting may be too low to activate the auto strike circuit. press the manual strike switch to ignite the lamp.
6. Measure the output voltage and current using the meters on the control panel. To read the voltage press the voltage switch.
7. Calculate the output power using the formula (volts) X (amps) = (watts). If the power level is over 10000 watts immediately turn off the light and go to step 8.
8. Allow the light to run at least 10 minutes before making any adjustments.
9. Turn off the light using the main power switch on the control panel. The cooling system will continue to run for at least 30 minutes after the power is turned off. Do not be concerned. The power to the power supply adjustment taps have been disconnected by the unit's main power contactor.

WARNING

All three terminal blocks in the coarse and fine adjustment groups must be set at the same letter or number tap setting on both the upper and lower power supplies. Failure to observe the correct tap settings will

result in shortened lamp life, excessive input current draw, and possible equipment damage.

10. Adjust the input voltage taps (TB-1)-(TB-6) to the same setting on both power supplies to set the output power level to 10000 Watts +/- 5%.
11. The taps on (TB-1-3) labeled W,X,Y,Z are coarse adjustments with tap (W) being the lowest current and tap (Z) being the highest current.
12. The taps on (TB-4-6) labeled 1,2,3,4 are fine adjustments with tap (1) being the lowest current and tap (4) being the highest current.
13. Be sure all the terminal block screws have been tightened then re-energize the unit using the main power switch.
14. Repeat steps 6 thru 13 until the power supply has been properly adjusted. When the adjustments are completed replace the lower access panel.

GLOBE MAINTENANCE

In order to insure maximum lamp life the following procedures should be followed every 75 - 100 hours of operation.

GLOBE ROTATION

If the fixture is used in a position other than pointed within 15 % of vertical the globe should be rotated 1/3 of a turn to insure even deposition of the vaporized tungsten generated by the arc inside the globe.

ADJUSTMENT PROCEDURES

1. Refer to the instructions for removal and installation of the globe noting all warnings.
2. Follow the disassembly procedure for a fixture with the globe installed steps 1 thru 5.
3. When rotating the globe for removal continue LIGHTLY pressing rearward on the globe. The threads of the globe will ride out of their current leads and drop into the next set of threads in the receiver block. When this happens you will feel the globe drop down into the receiver block.
4. Immediately stop turning the globe and reverse direction to screw the globe in at the new orientation.
5. Complete reinstalling the globe per the globe installation procedure.

POWER LEVEL ADJUSTMENT

Check the output power level of the system and readjust as necessary to maintain the output below 10000 watts. (SEE POWER ADJUSTMENT PROCEDURES)

CIRCUIT DESCRIPTIONS

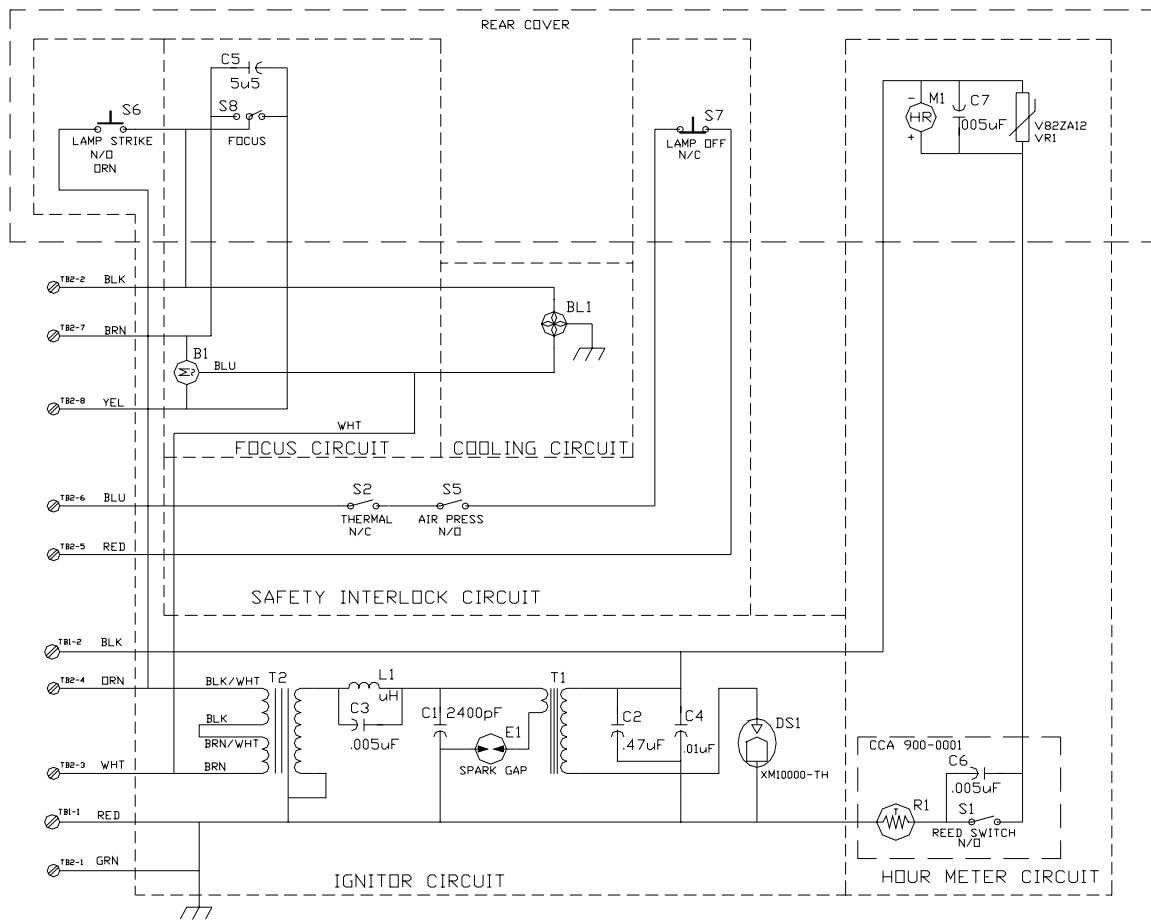

IGNITOR CIRCUIT THEORY OF OPERATION

When power is applied through the orange and white wires from pins 1 and 5 respectively of (P1) to the input step up transformer (T2) at 115 vac, 60 Hz, it causes the spark gap (E1) to break down. The rf trap (L1, C3) in the secondary of (T2) minimizes rf losses to the power line. The spark gap breakdown allows current to flow in the resonant circuit consisting of (C1) and the primary of (T1). A series of damped oscillations occur (at 2 to 4 MHz) during a portion of each half of the 60 Hz line frequency. These high frequency pulses are stepped up in voltage (to approximately 60 KV) thru (T1) and then applied to the lamp terminals. (C2, C4) provides a low impedance, rf return path for the high voltage pulse through the lamp. An arc is struck in the lamp ionizing the insulating xenon gas and when suitable DC power is available the lamp will ignite.

SAFETY INTERLOCK CIRCUIT THEORY OF OPERATION

The safety interlock circuit is composed of a thermal switch (S2) located on the lower right front spider arm and an air pressure switch (S5) located at the rear of the lamp head near the cooling blower.

If the lamp head becomes too hot to safely operate the lamp the thermal switch (S2) will open causing the ballast contactor (K1) to de-energize turning the lamp off. When the lamp head cools to a safe operating temperature the thermal switch (S2) will reset and the system will automatically relight.

If the lamp head cooling system becomes inoperative or becomes blocked with debris the air pressure switch (S2) will detect the drop in blower intake pressure and will open causing the ballast contactor (K1) to de-energize turning the lamp off. When the problem has been corrected and the cooling system is operating correctly the air pressure switch will reset and the system will relight.

7 KW POWER SUPPLY THEORY OF OPERATION

The xenon lamp power supply has two stages of operation. Before the lamp has lit the boost voltage circuit supplies 100 Vdc or more to the lamp. This boosted voltage enhances the initial ignition arc for several hundred milliseconds after the lamp has lit assuring a reliable ignition. Upon ignition of the lamp the main power supply takes over supplying low voltage and regulated constant high current.

The boost circuit functions as follows. The power supply transformer contains a set of high voltage low current auxiliary windings. These windings supply a minimum of 85 Vac. The voltage passes through the current limiting resistor (R1) and is full wave rectified by diodes (CR7,8,2,5). The rectified voltage is then stored in capacitors (C1, C2) until the ignitor circuit is energized.

The main power supply circuit functions as follows. The main three phase power enters the unit at the input terminals of the power contactor (K1). When the contactor is energized current flows through the power adjustment terminal boards (TB1 - 6) to the primary windings of the power transformer (T1). The power transformer steps down the input voltage and limits the output current to a range that is safe for the operation of the lamp that is attached to the power supply. The power transformer output is then rectified by the power diodes (CR1-6) and filtered by the output capacitors (C1-2). Capacitor (C3, C7) form a filter to protect the power diodes from high voltage spikes on the output power lines when the ignitor is energized.

When the ignitor circuit is energized a high voltage high frequency arc passes across the electrodes in the lamp ionizing the insulating xenon gas creating a path for the discharge of capacitors (C1, C2) through the lamp. As the capacitors discharge the current through the lamp increases. The current limiting resistor (R1) stops the effect of the boost circuit on the output of the power supply as the current increases. At the same time the main power supply continues supplying regulated constant current to the lamp. The output voltage of the main power supply is determined by the impedance of the lamp after it is lit.

The resistor (R3) limits the discharge current of capacitors (C1, C2) through the lamp during the ignition cycle preventing damage to the lamp due to excessive current. Once the output voltage of the power supply has dropped to the normal operating level relay (K6) de-energizes connecting capacitors (C1, C2) directly to the power supply output thereby increasing their filtering capability. Zener diode (CR9) is in series with the coil of (K6) to insure that relay (K6) releases during the lamp operation.

The circuit breaker (CB1) monitors the ripple current on the output of the power supply. When the lamp is running if one of the three phase input power lines fails or if one of the rectification or filter components fails the output ripple of the power supply will increase significantly. When the ripple current increases the circuit breaker will trip de-energizing the input power contactor (K1) thereby preventing damage to the lamp from the high ripple current.

The thermal switch (TS1) is located on the negative heatsink and monitors the output power diode temperature. When the heatsink temperature exceeds the safe maximum limit for the power diodes the switch will open de-energizing the input power contactor (K1) thereby preventing damage to the output power diodes from excessive operating temperature.

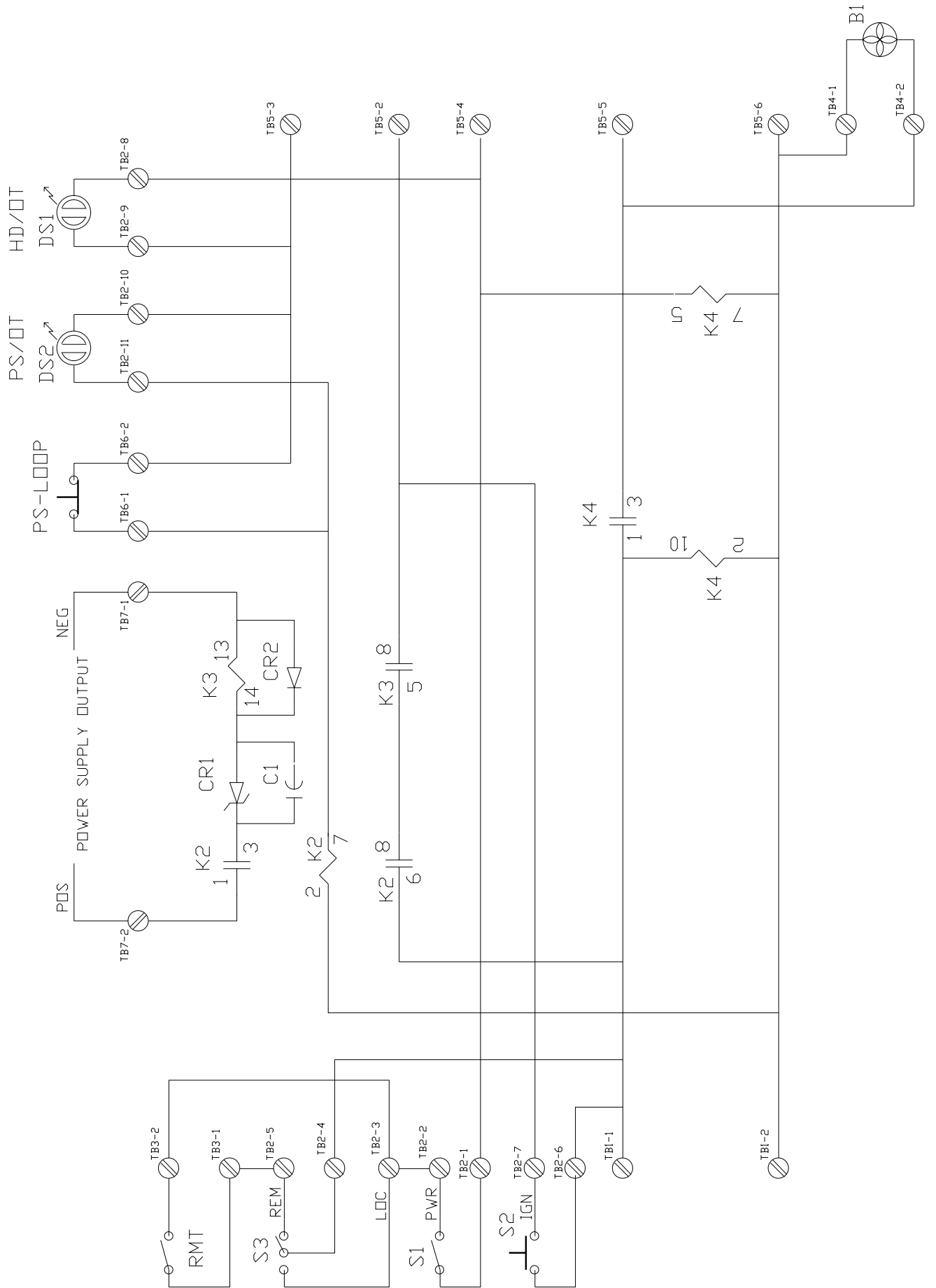

AUTO STRIKE CIRCUIT THEORY OF OPERATION

When the circuit supplying power to the power supply main contactor (K1) is energized current flows through the lamp power switch (S1) to (TB2-1) out (TB5-4) through the lamp head safety interlock circuit returns to (TB5-3) out (TB6-2) to the upper power supply terminal block (TB7-3) through the power supply safety interlock circuit (TS1,CB1) out (TB7-4) to the lower power supply terminal block (TB7-3) through the lower power supply safety interlock circuit (TS1,CB1) out (TB7-4) and splits off to the lower power supply main contactor coil (K1) through (TB7-2) to the coil of the auto strike time limit relay (K2) through (TB6-1) out (TB6-2) through the upper power supply terminal block (TB7-2) to the upper power supply main contactor coil (K1).

The auto strike time limit relay (K2) restricts the operation of the auto strike circuit to one minute after the system is energized by opening the circuit supplying power to the lamp head ignitor circuit (K2-6,8) and opening the circuit supplying power to the coil of the auto strike power relay (K3) (K2-1,3).

When the power supply is energized and the pre ignition output voltage is above 85 Vdc zener diode (CR11) breaks down allowing the current to flow through the coil of the auto strike power relay (K3). When the auto strike power relay (K3) actuates current flows through its contacts (K3-5,8) to (TB5-2) and out to the lamp head ignitor circuit. When the lamp head ignitor circuit energizes the output voltage of the power supply drops below the break down threshold of zener diode (CR11) causing the auto strike relay (K3) to de-energize opening the ignitor power circuit. If the lamp lights the output voltage of the power supply will remain below the break down threshold of zener diode (CR11) and the auto strike relay (K3) will remain de-energized. If the lamp does not light the output voltage of the power supply will recycle to above the zener diode (CR11) break down threshold and the auto strike power relay (K3) will reenergize. This cycle will repeat until the lamp lights or the auto strike time limit relay (K2) times out. Once the time limit is reached the auto strike circuit will not operate until the circuit supplying power to the main power supply contactors (K1) is de-energized and reenergized. If one of the system safety interlock circuits opens the power supply contactor circuit, upon resetting the auto strike cycle will reinitialize.

SYSTEM COOL DOWN CIRCUIT THEORY OF OPERATION

When the system main power is energized the current flows from the line side of the power supply contactor (K1) through circuit breaker (CB3) to autotransformer (T2) where the 230 Vac line is stepped down to 120 Vac. The current flows through circuit breaker (CB2) to (TB1-1) to the supply input (K4-10,2) and power contacts (K4-1,3) of cool down timing relay (K4).

When the circuit supplying power to the power supply main contactor (K1) is energized current flows through the lamp power switch (S1) to (TB2-1) and to the control input of cool down timing relay (K4-5,7). The cool down timing relay (K4) actuates closing its power contacts (K4-1,3). Current flows to (TB5-5) out to the lamp head cooling circuit and to (TB4-2) out to the power supply cooling fan. When the circuit supplying to the power supply main contactor (K1) is de-energized the removal of power to the cool down timing relays control input (K4-5,7) causes the cool down timing relay (K4) to start its timing cycle. Thirty minutes after the control input is de-energized the cool down timing relay (K4) will open its power contacts (K4-1,3) de-energizing the lamp head and power supply cooling circuits.

