



BRITELIGHT[®]

**4000 SYSTEM
OPERATING MANUAL**

REV 1.4

COPYRIGHT © 1996 Xenotech, Inc.

**INSTRUCTIONS FOR REMOVING AND INSTALLING A TYPE XT XENON BULB IN A
BL4000 FIXTURE**

NOTE

FAMILIARIZE YOURSELF WITH THE LOCATION AND IDENTIFICATION OF THE COMPONENTS OF THIS SYSTEM AND ALSO THE NORMAL OPERATION OF THE SYSTEM BEFORE ATTEMPTING ANY ADJUSTMENT OR SERVICE.

NOTE

COMPLETELY READ THROUGH AND HAVE A GOOD UNDERSTANDING OF THE PROCEDURES BEFORE ATTEMPTING TO SERVICE THIS SYSTEM. FAILURE TO DO SO MAY RESULT IN FATAL INJURY OR EQUIPMENT DAMAGE.

WARNING

DISCONNECT POWER SOURCE BEFORE SERVICING THIS EQUIPMENT.

WARNING

A PROTECTIVE JACKET, FULL FACE SHIELD, AND PROTECTIVE GLOVES MUST BE WORN AT ALL TIMES WHEN THE LAMPHEAD IS OPENED WITH A BULB INSTALLED, OR WHEN HANDLING THE XENON BULBS. SERIOUS INJURY MAY OCCUR IF PROPER SAFETY PRECAUTIONS ARE NOT OBSERVED. READ ALL ENCLOSED INSTRUCTIONS AND INFORMATION SHEETS BEFORE HANDLING THE BULB.

WARNING

NEVER OPERATE A FIXTURE WITH AN EXPOSED BULB! THERE IS AN EXTREME DANGER OF SEVERE BURNS TO EXPOSED SKIN AND EYES FROM THE ULTRAVIOLET LIGHT EMITTED FROM THE EXPOSED BULB. DAMAGE CAN OCCUR IN AS LITTLE AS 30 SECONDS OF EXPOSURE. THERE IS ALSO AN ADDITIONAL DANGER FROM FLYING QUARTZ IF AN EXPOSED BULB EXPLODES!

EQUIPMENT REQUIRED

1. PROTECTIVE SAFETY EQUIPMENT KIT
2. 7/16", 5/16", 3/8" OPEN END WRENCH
3. ALLEN WRENCH 5/32"
4. PHILLIPS SCREWDRIVER #2

DISASSEMBLY PROCEDURE

IF THERE IS NO BULB INSTALLED IN THE FIXTURE

1. Remove the 8 screws located on the small sides of the front cowling using a #2 phillips screwdriver and remove the cowling.
2. Remove the 2 brass bolts connecting the short leads to the front lamp holder using a 7/16" wrench.
3. Remove the center mounting screw, washer, and spring from the spider using a 5/32" allen wrench while supporting the front lamp holder so that it does not fall when the screw is removed.
4. Remove the lamp holder from the fixture.
5. Disconnect the focus rod swivel joint from the spider arm using the 5/16" and 3/8" open end wrenches. Do not turn the swivel joint or focus rod.
6. To disassemble the front lamp holder remove the 2 clamp retaining screws located on the side of the lamp swivel hub using a 5/32" allen wrench and remove the clamp.

DISASSEMBLY PROCEDURE

IF THERE IS A BULB IS INSTALLED IN THE FIXTURE

1. Remove the 8 screws located on the small sides of the front cowling using a #2 phillips screwdriver and remove the cowling.

CAUTION

DO NOT PLACE ANY EXCESSIVE FORCE ON THE GLOBE WHILE REPLACING THE PROTECTIVE WRAPPER!

2. Wrap the bulb securely in the protective wrapper that the bulb was originally shipped in.
3. Remove the 2 brass bolts connecting the short leads to the front lamp holder using a 7/16" wrench.
4. Disconnect the focus rod swivel joint from the spider arm using the 5/16" and 3/8" open end wrenches. Do not turn the swivel joint or focus rod.
5. Remove the center mounting screw washer and spring from the spider using a 5/32" allen wrench while supporting the front lamp holder so that the bulb does not drop when the mounting screw is removed.

WARNING

DO NOT EXERT EXCESSIVE FORCE ON THE BULB WHILE UNSCREWING IT FROM THE REAR LAMP HOLDER! THE BULB SHOULD RELEASE FROM THE REAR LAMP HOLDER WITH A VERY LIGHT COUNTER CLOCKWISE ROTATION. IF THIS DOES NOT HAPPEN, SEE THE PROCEDURE FOR REMOVING A "FROZEN" BULB.

6. Remove the bulb by lightly pushing back on the bulb to move the rear lamp holder to its rearmost position while lightly turning the bulb in a counterclockwise rotation. The bulb will release from the rear lamp holder in approximately 1.5 complete turns.
7. Remove the bulb with the front lamp holder attached from the fixture and place it on a stable working surface for the removal of the front lamp holder.
8. To remove the front lamp holder from the bulb, remove the 2 clamp retaining screws located on the side of the lamp swivel hub using a 5/32" allen wrench and remove the clamp.
9. Remove the lamp holder from the bulb and place the bulb into its shipping container for safekeeping. Resecure the protective wrapper if necessary.

ASSEMBLY PROCEDURE

WARNING

DO NOT REMOVE THE PROTECTIVE COVER FROM THE LAMP UNTIL INSTRUCTED TO DO SO!

WARNING

DO EXERT ANY FORCE ON THE QUARTZ PORTIONS OF THE BULB AT ANY TIME!

NOTE

IF THE FRONT LAMP HOLDER HAS NOT BEEN DISASSEMBLED, SEE THE LAST STEPS IN THE APPROPRIATE DISASSEMBLY INSTRUCTIONS.

1. Untie the cord on the anode end of the protective cover. Do not remove the cover at this time!
2. Fasten front lamp holder to the bulb by placing the anode end (large electrode) of the lamp in the lamp holder and aligning the stud on the end of the lamp ferrule with the channel in the nose of the lamp holder body. Slide the lamp completely down the channel as far as it will go.
4. Replace the clamp and reinstall the 2 clamp retaining screws located on the side of the lamp swivel hub using a 5/32" allen wrench.
5. Install the bulb into the fixture by inserting the cathode end of the lamp through the opening in the reflector.
6. Insert the end of the lamp ferrule into the opening in the rear lamp holder receiver block and align the threads by turning the bulb counterclockwise until the bulb threads drop into the receiver threads.

NOTE

DO NOT OVERTIGHTEN THE LAMP IN THE RECEIVER BLOCK AS THIS MAY CAUSE THE LAMP TO "FREEZE" IN THE RECEIVER BLOCK MAKING IT DIFFICULT TO REMOVE. TIGHTEN THE LAMP JUST ENOUGH TO APPLY SPRING PRESSURE TO THE THREADS BUT NOT SO MUCH AS TO BOTTOM OUT THE LAMP FERRULE COMPLETELY AGAINST THE RECEIVER BLOCK.

7. Gently rotate the bulb clockwise until resistance is felt.
8. At this point the bulb should be in contact with the spring plunger assemblies. Gently turn the bulb an additional 1/16-1/8 of a turn to load the threads with the spring plungers.
9. Secure the front lamp holder to the spider with the shoulder bolt, spring, and washer that was removed during disassembly.
10. Reconnect the focus rod swivel joint to the spider arm using the 5/16" and 3/8" open end wrenches. Do not turn the swivel joint or focus rod.
11. Reconnect the 2 short leads from the spider to the front lamp holder using the 2 brass bolts and washers that were removed during disassembly.

NOTE

ANY TYPE OF ALCOHOL IS SUITABLE FOR CLEANING THE XENON BULB EXCEPT FOR ALCOHOL THAT HAS BEEN DENATURED USING PETROLEUM PRODUCTS SINCE THE DENATURING AGENT WILL LEAVE A RESIDUE ON THE BULB.

12. Remove the protective cover from the bulb and clean the quartz portion of the bulb completely with alcohol.
13. Reinstall the front cowl using the screws that were removed during disassembly.
14. Log the hour meter reading at installation.
15. Test the lamp operation and preform the output power adjustment procedure.

REMOVING A "FROZEN" BULB

1. Replace the front lamp holder retaining bolt to support the front of the bulb while freeing the bulb from the rear lamp holder.
2. Remove the fixture rear cover by removing the 10 screws around the perimeter of the sides using a #2 phillips screwdriver and pulling the cover straight back using the rear handle.
3. Disconnect the rear panel wiring connectors from the head wiring harness then set the cover aside.
4. Remove the plenum access cover by removing the 10 screws from around the cover using a #2 phillips screwdriver and remove the cover.

WARNING

DO EXERT ANY FORCE ON THE QUARTZ PORTIONS OF THE BULB WHILE ATTEMPTING TO FREE IT FROM THE REAR LAMP HOLDER!

5. Reach around the rear lamp holder assembly and grasp the bulb by its rear metal ferrule, and while lightly pulling the bulb back into the receiver block, turn the bulb in a clockwise direction until the bulb begins to rotate freely.
6. Once the bulb is free, *do not* remove it completely from the rear lamp holder.
7. Replace the plenum cover, rear panel wiring, and fixture rear cover.
8. Return to step 5 of :

"DISASSEMBLY PROCEDURE
IF THERE IS A BULB IS INSTALLED IN THE FIXTURE"

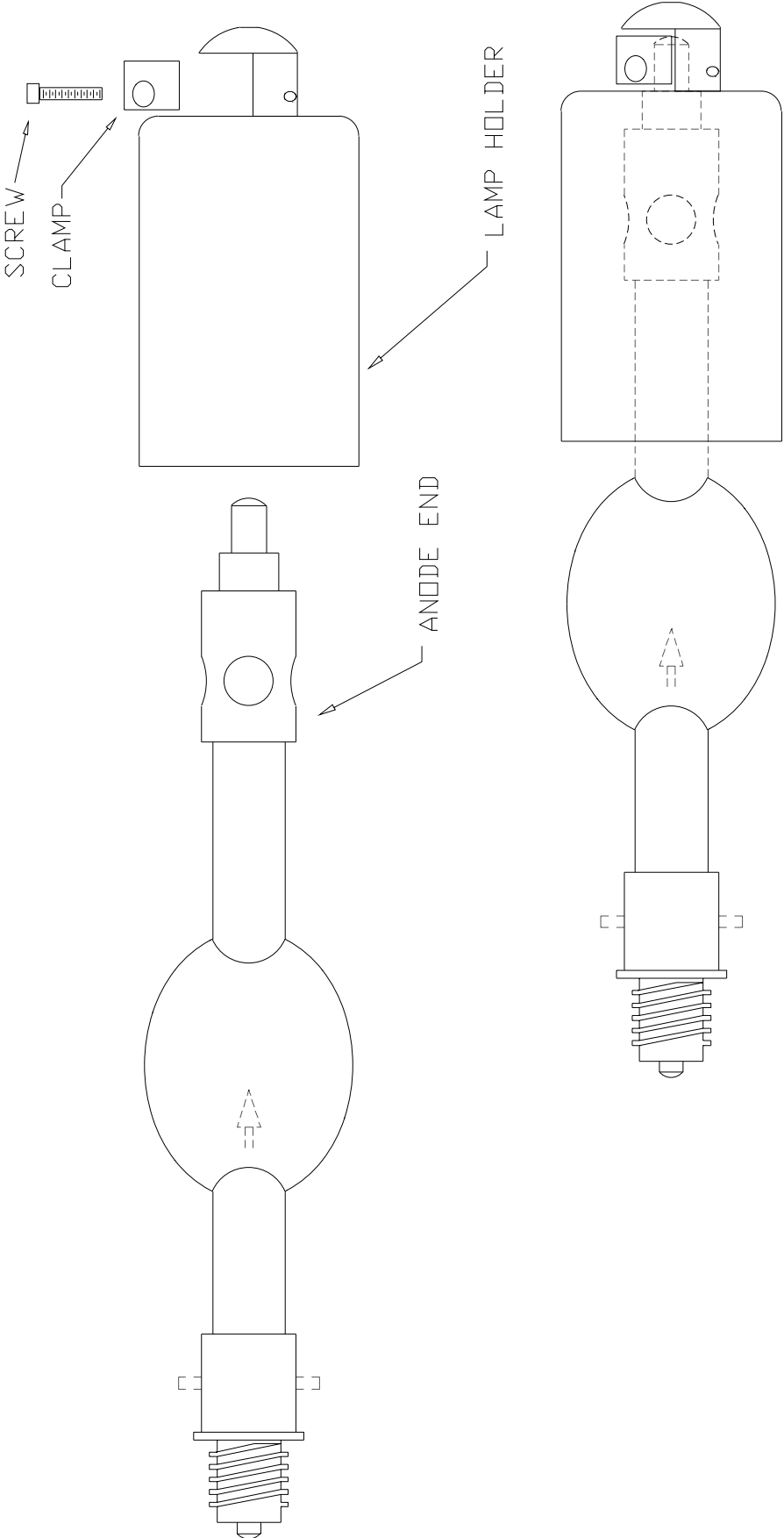

FRONT LAMP HOLDER ASSEMBLY

POWER INPUT CONNECTOR WIRING INSTRUCTIONS

The input power requirements for a 4 kW solid state power supply are as follows.

VOLTAGE NOMINAL	230 VAC
FREQUENCY RANGE	47 - 63 HZ
INPUT CURRENT	1 PHASE 37 AMPS
MINIMUM INPUT WIRE SIZE	8 AWG

CONNECTIONS

SINGLE PHASE OPERATION

CONNECTOR TERMINAL	LINE DESIGNATION	WIRE COLOR
A	PHASE A OR HOT	BLACK
B	PHASE B OR NEUTRAL	WHITE
C	N/C	N/C
D	SAFETY GROUND	GREEN

ABRIDGED OPERATING INSTRUCTIONS FOR 4 KW XENON SYSTEM

CONNECTIONS

1. Connect lamp head to the lamp head connector located on the front panel marked DC OUTPUT.
2. Connect the power cord to the AC input power connector located on the front panel marked AC INPUT.
3. When the power is energized the indicator lights next to the input power connector will light indicating the following.

GREEN LIGHT : SAFETY GROUND and phase A power input lines are correctly connected.

AMBER LIGHT : 230 VAC input is connected across the A & B phase input pins and energized.

BLUE LIGHT : AUX 120 VAC supply is energized.

4. When the connections are correct the blower in the lamp head will operate and the top indicator light next to the dc output connector will light indicating the following.

RED LIGHT : SAFETY CIRCUIT FAULT lights until the pressure in the lamp head cooling system is adequate to cool the lamp. This indicator will also light if any one of the following conditions occur: head overtemperature, door interlock switch activated, cooling system failure, or an open connection in the safety circuit.

LIGHT OPERATION

1. Place the main power circuit breaker in the on position the indicator lights next to the output power connector will light indicating the following.

GREEN LIGHT : MODULE A READY indicates that the first high current low voltage power supply is ready to run the lamp after ignition.

GREEN LIGHT : MODULE B READY indicates that the second high current low voltage power supply is ready to run the lamp after ignition.

GREEN LIGHT : BOOST READY will light 5 -10 seconds after the power switch has been turned on indicating that the open circuit output voltage is over 100 VDC and the supply is ready to ignite the lamp. The lamp can be ignited before this indicator has lit if necessary.

Once the power supply is energized by this switch steps 2 - 4 may be preformed either at the power supply or the rear of the lamp head.

2. Move the lamp switch to the on position. When the lamp lights release the lamp switch. If the lamp does not light immediately release the switch wait 5 seconds or until the boost ready indicator lights and re-try.

3. Focus the light for the desired effect by moving the focus switch to the forward or reverse position and holding the switch. The focus mechanism works on a cam action and will cycle from full flood to full spot until the focus switched is released. Moving the switch to the opposite position will reverse the focus action.
4. To turn off the light move the lamp switch to the off position. If the light is not going to be immediately reused DE-energize the power supply.
5. To DE-energize the power supply place the main power circuit breaker in the off position.

CAUTION

DO NOT DISCONNECT THE MAIN POWER UNTIL THE BULB HAS COMPLETELY COOLED. THE LAMPHEAD COOLING SYSTEM WILL RUN WHENEVER THE MAIN POWER LINES ARE ENERGIZED.

CAUTION

THE POWER SUPPLY CONTAINS A CAPACITOR BANK ACROSS THE OUTPUT TERMINALS. THE ENERGY STORED IN THE CAPACITORS MAY BE PRESENT FOR SEVERAL MINUTES AFTER THE POWER SUPPLY IS DE-ENERGIZED.

NOTE

THE AUXILIARY 120 V.AC POWER SUPPLY IS PROTECTED BY THE 5 AMP CIRCUIT BREAKER LOCATED ON THE FRONT PANEL. THIS CIRCUIT SUPPLIES POWER FOR THE COOLING SYSTEM, BOOST VOLTAGE SUPPLY, FOCUS, AND IGNITION CIRCUIT.

NOTE

THE LAMP HEAD AND POWER SUPPLY ARE THERMALLY PROTECTED. THE LAMPHEAD IS ALSO PROTECTED BY AN AIR PRESSURE SWITCH. IF THE COOLING SYSTEM FAILS OR THE EQUIPMENT IS USED IN AN EXCESSIVELY HOT ENVIRONMENT, THE LAMP WILL SHUT OFF TO PREVENT DAMAGE. IF THE FAULT IS LOCATED IN THE HEAD, THE SAFETY CIRCUIT FAULT INDICATOR ON THE FRONT PANEL WILL LIGHT AND WILL REMAIN LIT UNTIL THE FAULT CONDITION IS CLEARED . IF THE POWER SUPPLY OVERHEATS THE MODULE A OR B READY INDICATORS WILL GO OUT AND WILL REMAIN UNLIT UNTIL THE POWER SUPPLY COOLS TO A SAFE OPERATING TEMPERATURE. IT IS POSSIBLE FOR ONLY ONE POWER MODULE TO SHUT DOWN. WHEN THIS HAPPENS IT IS POSSIBLE FOR THE LAMP TO RUN AT HALF POWER UNTIL THE SECOND MODULE SHUTS DOWN OR THE FIRST MODULE COOLS AND AUTOMATICALLY GOES BACK ON LINE. WHEN THE INDICATORS RETURN TO A NORMAL STATE THE LAMP MAY BE RE-STRUCK.

CAUTION

DISCONNECT THE INPUT POWER CONNECTOR BEFORE REMOVING THE ACCESS PLATES. DANGEROUS VOLTAGE IS PRESENT IN THIS EQUIPMENT.

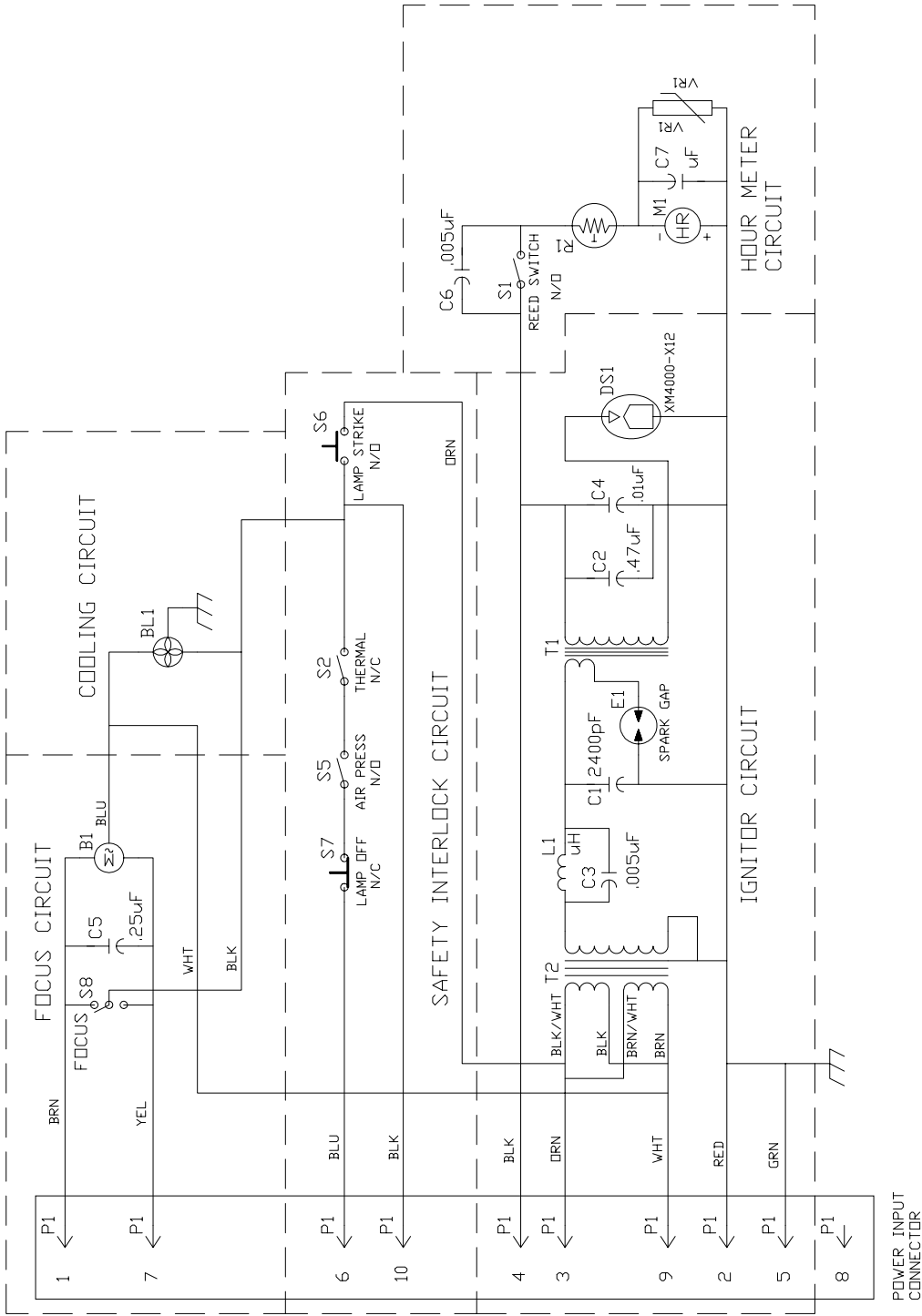

SCHEMATIC 4KW HEAD

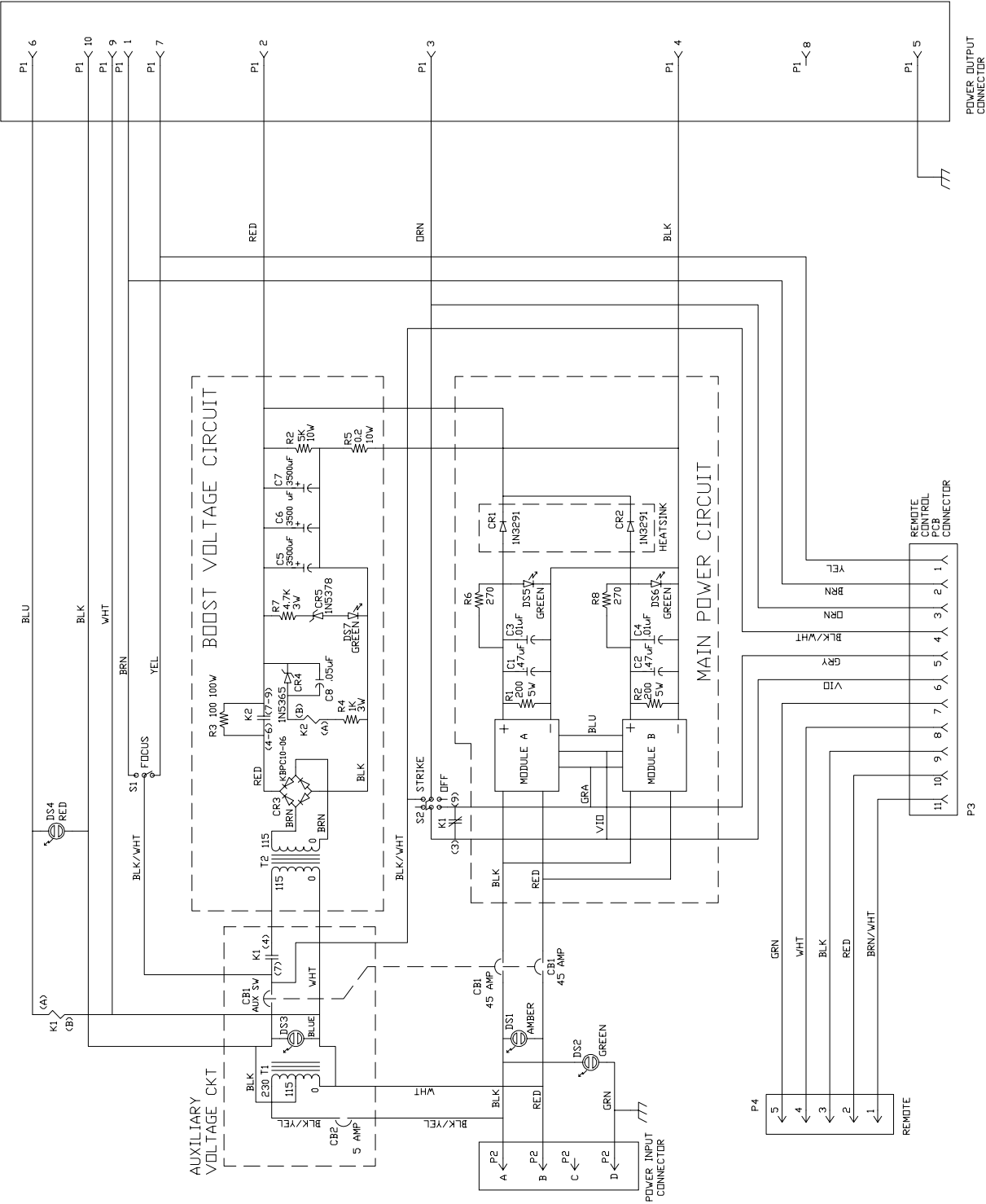

SCHEMATIC 4KW SOLID STATE POWERSUPPLY

INSTALLATION AND CALIBRATION FOR 4kW POWER MODULE

CAUTION

INSPECT SYSTEM WIRING FOR ANY CONDITION THAT MAY HAVE CAUSED MODULE FAILURE AND CORRECT CONDITION BEFORE INSTALLING NEW MODULE.

MODULE REMOVAL

1. REMOVE TOP COVER FROM THE POWER SUPPLY BY ROTATING THE INTERNAL COVER LATCHES LOCATED ON THE REAR AND SIDES OF THE POWER SUPPLY. (USE THE WRENCH SUPPLIED WITH THE UNIT)
2. REMOVE THE 8 SCREWS RETAINING THE FRONT PANEL.
3. REMOVE THE CHASSIS RETAINING HARDWARE.
4. LIFT THE CHASSIS AND FRONT PANEL FROM THE CASE.
5. REMOVE THE WIRING FROM THE DEFECTIVE MODULE WHILE NOTING THE CONNECTIONS FOR REASSEMBLY.
6. REMOVE THE 4 RETAINING SCREWS FROM THE BOTTOM OF THE CHASSIS UNDER THE DEFECTIVE MODULE AND SLIDE THE MODULE FORWARD AND LIFT FROM THE CHASSIS.

MODULE INSTALLATION

1. REVERSE MODULE REMOVAL PROCEDURE STEPS 6 - 3 DO NOT ATTACH THE FRONT PANEL UNTIL THE CALIBRATION IS COMPLETE.

POWER SUPPLY CALIBRATION

CAUTION

THE POWER SUPPLY CALIBRATION PROCEDURE REQUIRES THE UNIT TO BE ENERGIZED WHILE BEING CALIBRATED. USE EXTREME CAUTION DURING THE CALIBRATION NOT TO COME IN CONTACT WITH THE LIVE CONNECTIONS ON THE FRONT PANEL AND CHASSIS. VOLTAGES FROM 240 VAC TO 160 VDC MAY BE PRESENT ON THE INPUT AND OUTPUT WIRING WHENEVER THE UNIT MAIN INPUT POWER LINES ARE ENERGIZED.

WARNING

POTENTIAL SHORT CIRCUIT CONDITION

DO NOT ALLOW THE TERMINALS OF THE MAIN CIRCUIT BREAKER TO COME IN CONTACT WITH THE FRONT PANEL MOUNTING RAILS.

EQUIPMENT REQUIRED

DC VOLT METER 0 - 200 V.DC
DC CLAMP-ON AMMETER 0 - 200 A.DC

CALIBRATION

1. ATTACH THE LAMP HEAD TO THE POWER SUPPLY OUTPUT CONNECTOR USING A 50 FT. HEAD EXTENSION AND POINT THE LAMP HEAD STRAIGHT UP.
2. ATTACH THE POWER FEEDER TO THE POWER INPUT CONNECTOR.
3. CONNECT THE AMMETER AROUND THE LARGE RED CABLE RUNNING FROM THE HEATSINK TO THE OUTPUT CONNECTOR.
4. CONNECT THE POWER FEEDER TO THE POWER LINE AND SET THE MAIN BREAKER TO THE ON POSITION.
5. MEASURE THE VOLTAGE ACROSS THE OUTPUT TERMINALS OF EACH POWER MODULE AND ADJUST THE VOLTAGE TO 35.5 V.DC USING THE VOLTAGE ADJUSTMENT LOCATED AT THE LOWER LEFT OF THE FRONT OF THE MODULE.
6. REMOVE THE VOLTMETER FROM THE CIRCUIT AND STRIKE THE LIGHT.
7. READ THE OUTPUT CURRENT ON THE AMMETER. IF THE CURRENT IS OVER 135 AMPS AFTER 30 SECONDS, TURN OFF THE LIGHT AND TURN THE CURRENT ADJUSTMENTS LOCATED ON THE CENTER OF EACH MODULE 1/2 TURN CCW.

8. RESTRIKE THE LIGHT AND REPEAT STEP 7 UNTIL THE CURRENT IS LESS THAN 135 AMPS.
9. ONCE THE START CURRENT IS SET, ALLOW THE LAMP TO BURN FOR AT LEAST 5 MINUTES OR UNTIL THE CURRENT READING STABILIZES.
10. AFTER THE SYSTEM HAS STABILIZED, CONNECT THE VOLTMETER POSITIVE LEAD TO THE POSITIVE TERMINAL OF EITHER MODULE AND THE NEGATIVE LEAD TO THE NEGATIVE TERMINAL OF EITHER MODULE.
11. CALCULATE THE TOTAL SYSTEM OUTPUT POWER USING THE FORMULA $E \times I = W$. WHERE E = OUTPUT VOLTAGE, I = OUTPUT CURRENT, W = OUTPUT POWER IN WATTS. THE SYSTEM SHOULD BE SET TO RUN BETWEEN 3950 - 3999 WATTS.

CAUTION

THE INDIVIDUAL POWER OUTPUT OF A SINGLE MODULE MUST NOT EXCEED 2000 WATTS. EXCEEDING THE MAXIMUM POWER LIMIT MAY DAMAGE THE MODULE.

12. BALANCE THE CURRENT OUTPUT OF EACH MODULE BY ATTACHING THE AMMETER AROUND THE SMALLER RED LEAD RUNNING FROM EACH MODULE TO THE DIODES ON THE HEATSINK ONE AT A TIME. THE INDIVIDUAL MODULE CURRENT SHOULD BE ADJUSTED TO 50% OF THE TOTAL SYSTEM OUTPUT CURRENT USING THE CURRENT ADJUSTMENTS ON EACH MODULE. THE TYPICAL SETTING FOR EACH MODULE IS AROUND 65 AMPS.
13. RECHECK THE TOTAL SYSTEM OUTPUT POWER AND VERIFY THAT THE POWER LEVEL IS STILL BETWEEN 3950 - 3999 WATTS. (PER STEPS 9 - 11).
14. THE SYSTEM CALIBRATION IS NOW COMPLETE. TURN THE LAMP OFF AND ALLOW THE GLOBE TO COOL AT LEAST 5 MINUTES. DISCONNECT THE MAIN INPUT POWER LINE AND REPLACE THE FRONT PANEL AND TOP COVER.