

INSTRUCTION MANUAL

XENON GLADIATOR II

Follow Spotlight

Type 47050

Rev. 3/98



STRONG INTERNATIONAL

a division of Ballantyne of Omaha, Inc.
4350 McKinley Street
Omaha, Nebraska 68112 USA
Tel 402/453-4444 • Fax 402/453-7238

PREFACE

THE STRONG INTERNATIONAL XENON GLADIATOR II Model 47050 is a direct current follow spotlight complete with a xenon lamphouse, power supply, optical system, color boomerang, and base stand assembly. The spotlight assembly consists of the arc lamp, variable focus lens system, color boomerang, and base. The separate xenon power supply completes the installation.

ONLY THE SPECIAL XENON POWER SUPPLIES manufactured by Strong International can be used with the Gladiator II. For installation and operation of the power supply, see the instruction manual furnished separately.

THE XENON LAMPHOUSE utilizes a 2500 watt xenon bulb designed for horizontal operation, and a deep ellipse metal reflector as a light source. The reflector is designed to operate in a fixed position, and is dichroic ("cold") coated to reduce heat in the projected light. A lens blower and heat filters, mounted in the spotlight optical system, further reduce heat at the projection lens and color media.

ONLY XENON BULBS designed for horizontal operation should be used in this follow spot. Those bulbs presently approved for the Gladiator II include the Hanovia® XH2500HS, the Osram® XBO2500W/HS OFR, and the ORC® XM2500HS. All required bulb cabling is provided in the xenon lamphouse, and bulb adapters are not required.

ADJUSTMENT CONTROL for the xenon bulb is located at the rear of the lamphouse behind the access panel. The adjustments control the horizontal, vertical and focal movement of the bulb.

INSTRUMENTATION of the lamphouse includes a running time meter and a DC ammeter. The running time meter indicates the number of hours the bulb has been in operation. The ammeter displays the operating current of the lamp. A push button switch, located below the ammeter, changes the meter reading to indicate the DC voltage at the arc.

THE LAMPHOUSE COOLING BLOWERS are internally wired and operate on AC voltage derived from the xenon power supply. These blowers are required to maintain a safe operating temperature at the bulb seals. The blowers operate continuously until the xenon power supply is de-energized. Air flow interlock switches prevent operation of the lamp if the intake or exhaust blowers are not operating or failing to move adequate air.

THE IGNITER is equipped with an emergency ignition switch, located on the top of the lamphouse below the plug button. Pressing this switch bypasses the relay contacts on the igniter printed circuit board. DO NOT hold this switch for longer than **one second** to prevent transformer damage.

THE TWO ROCKER SWITCHES on the instrument panel are labeled MODE and LAMP. The MODE switch permits operation of the lamphouse from a remote location when placed in the "AUTO" position, or by the operator at the lamphouse when in "MAN." The normal setting for this switch, in a follow spot application, is in the "MAN." position.

THE LAMP SWITCH is provided for manual bulb ignition when the MODE switch is in the "MAN." position. The LAMP switch must also be "ON" to complete the ignition circuit when operating from a remote location.

THE LAMPHOUSE is supplied with a 13 foot cable containing the DC leads, the AC control wires, and the ground wire. The cable terminates in a multiple pin MS connector keyed to mate with the receptacle on the power supply.

WHEN TRANSPORTING THE SPOTLIGHT, it is necessary to remove the xenon bulb and place it in its original shipping container to prevent breakage. See the SAFETY PROCEDURES section following, and permit only authorized personnel to handle the xenon bulb.

IF AT ANY TIME you have a suggestion, or desire aid in securing anticipated results, write directly to STRONG INTERNATIONAL, 4350 McKinley Street, Omaha, Nebraska 68112.

INSTALLATION AND SETTING UP SPOTLIGHT

THE XENON GLADIATOR II is shipped in sections which must be assembled. Lifting straps on the yoke assembly permit assembling the spotlight on the floor and later hoisting it to an elevated position.

ASSEMBLE THE FOUR BASE LEGS to the lower square section of the base column using the 3/8-16 x 2-3/4 inch hex head cap screws and lockwashers provided. Insert a leveling foot and locknut in each of the four leg brackets and level the base before continuing the installation.

WHEN INSTALLED in a permanent location, the leveling feet must be removed, and the clearance holes in the base leg brackets used for hardware (user supplied) to bolt the base to the floor or platform. If it is desired to have the unit portable, when operating, the leveling feet *must* be adjusted down until the weight of the spotlight has been shifted from the casters to the leveling feet.

THE INNER TUBE and support yoke has three holes to permit adjusting the height of the spotlight. The three holes are on four inch centers and will allow an optical height of approximately 53 inches, 57 inches, and 61 inches above floor level to the optical center of the lamphouse and lens system. The leveling feet may be adjusted through an additional two inch range. Insert the height location pin through the hole in the outer tube and one of the holes in the inner tube.

THE HORIZONTAL SWING and vertical tilt locking knobs are on the right hand (operating) side of the yoke assembly. Tighten both of these locking devices securely before attempting to place the lamphouse and lens system on the support yoke.

PLACE THE LAMPHOUSE and lens system on the yoke assembly, with the spot size control handle to the right hand (operating) side, the same as the locking controls on the yoke. Line up the four mounting holes in the bottom of the base rail with the four mating holes in the support yoke and secure using the four sets of 3/8-16 screws, nuts and washers.

ATTACH THE LAMPHOUSE CABLE CONNECTOR to the mating receptacle on the power supply. The lamphouse and power supply connectors are keyed for correct pin alignment; make certain pins are seated before tightening the locking ring. DO NOT energize the xenon power supply before the xenon bulb is correctly installed into the lamphouse.

EARLIER MODELS of Strong xenon spotlights included a heavy-gauge green ground wire in the lamphouse cable assembly. This ground wire was attached to a ground stud connected to the power supply cabinet. Current models of Strong power supplies include a 1/4-20 stud in the cabinet adjacent to the MS connector to allow ground termination of older spotlights.

LAMPHOUSE - POWER SUPPLY

Interconnection Diagram

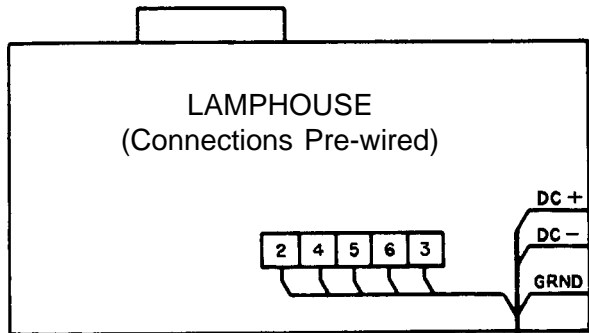

MS CONNECTOR

Pin	Wire No.
A	DC-
B	DC+
C	2
D	3
E	4
F	5
G	6
I	7
J	8
M	Grnd

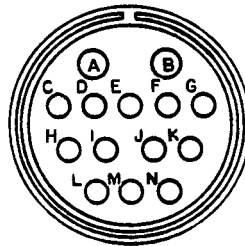

Lamphouse
Cable Assembly

Conduit

Remote - Auto
Sustained 5 Amp.
Dry Contact
(by Installer)

SYSTEM MUST BE GROUNDED
All wiring must conform to local
codes; shield lamphouse cable in
conduit if required.

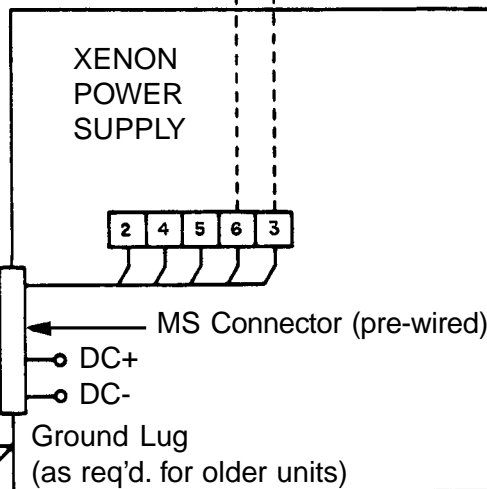

MS Connector (pre-wired)

DC+

DC-

Ground Lug

(as req'd. for older units)

SAFETY PROCEDURES



READ CAREFULLY BEFORE INSTALLING XENON BULB



THE XENON BULB is highly pressurized. When ignited, the normal operating temperature of the bulb increases the pressure to a level at which the bulb may explode if not handled in strict accordance to the manufacturer's operating instructions.

THE BULB is stable at room temperature, but may still explode if dropped or otherwise mishandled. Breakage resulting from transport and handling is *not* covered by the bulb manufacturer's warranty, and it is strongly recommended to disassemble the xenon bulb when transporting the spotlight.

REFER bulb replacement and service to QUALIFIED PERSONNEL with adequate protective clothing (face shield, clean cotton gloves, welder's jacket). For routine lamphouse service, observe the following rules:

1. Allow the bulb to cool to room temperature before opening the lamphouse. Put on protective clothing described above.
2. De-energize the xenon power supply at the AC source before opening the lamphouse compartment.
3. When possible, encase the bulb in its protective cover when cleaning or servicing the lamphouse interior. The bulb, when outside the lamphouse, must be encased in the cover.
4. Clean the bulb after it has cooled to room temperature. Do not touch the quartz envelope of the bulb; fingerprints will burn in and create hot spots which may shorten bulb life. If fingermarks are made, they should be carefully removed with methyl alcohol and cotton prior to bulb operation.
5. Never view an ignited bulb directly. **BLINDNESS OR PERMANENT EYE DAMAGE MAY BE INCURRED.**
6. Use only xenon bulbs designated as OZONE FREE. When possible, vent the lamphouse exhaust to outside atmosphere.
7. Maintain the lamphouse blower in good operating condition. Keep the blower inlet clean for unrestricted air flow.
8. To insure maximum bulb life, operate the lamphouse blower and the exhaust system for **at least** ten minutes after extinguishing the bulb.
9. If returning a bulb for warranty adjustment, pack it in its original shipping container. Complete and return all required warranty information.

10. Dispose of expired bulbs that are beyond warranty in the following manner: Wrap the bulb tightly in several layers of canvas or heavy cloth. Place it on a hard surface and shatter the envelope with a sharp hammer blow. DO NOT place an unshattered bulb in an ordinary refuse container.
11. DO NOT PERMIT UNAUTHORIZED PERSONNEL TO PERFORM OR ATTEMPT ANY PHASE OF XENON BULB HANDLING OR SERVICE.

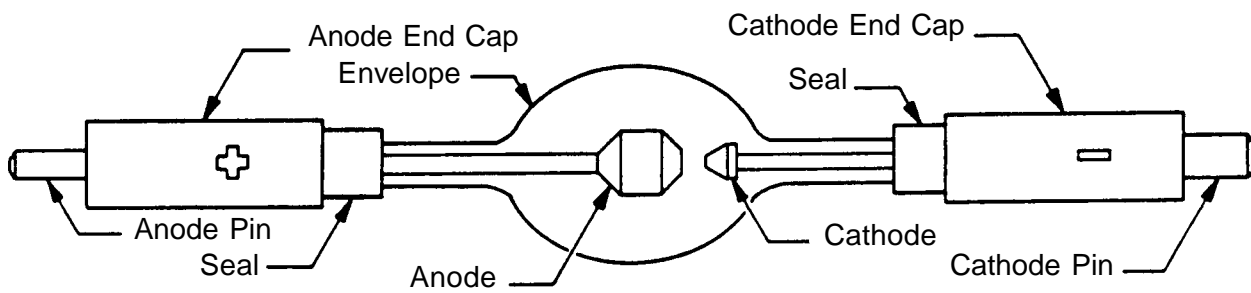

BULB INSTALLATION

OBSERVE ALL SAFETY PROCEDURES when working around the xenon bulb. Open the lamphouse access door by removing the tamperproof screws using the special screwdriver supplied. The igniter lead and contact clamp are tied off for shipping. Free the clamp and slide it over the rear bulb support collet.

THE BULB SUPPORT YOKE in front of the reflector has three horizontal positioning holes to permit setting the height of the yoke. The Gladiator II uses only the upper two holes. The spotlight is shipped set up for use with the Hanovia XH2500HS bulb normally supplied with the unit, and the spring pin is through the top hole. Because of a different end cap dimension, the bulb yoke must be raised and the pin installed in the center hole if an Osram XBO2500W/HS bulb is used. The yoke may be repositioned by loosening the 8-32 set screw in the support post. Tighten the set screw after setting the yoke position.

REMOVE THE PLASTIC PROTECTIVE COVER from the xenon bulb only if necessary. Handle the bulb by the metal end caps *only*. Insert the bulb into the lamphouse, passing the anode (+) end cap through the center hole of the reflector. Take care not to bump or scratch the surface of the reflector.

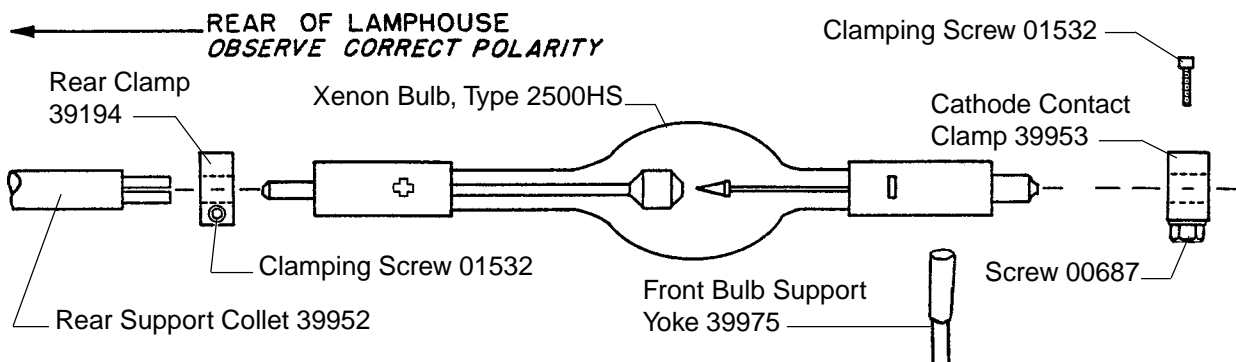

INSERT THE ANODE (+) PIN into the rear support collet and contact clamp. Rest the cathode (-) end cap in the front bulb support yoke. Seat the anode (+) pin into the rear support collet as far as possible for correct focus travel. Securely tighten the socket head clamping screw in the anode contact.

REST THE CATHODE END CAP in the "V" of the bulb yoke. Install the cathode contact clamp over the cathode (-) pin. Firmly tighten the socket head clamping screw for a secure electrical contact. Dress the negative DC lead attached to the contact clamp directly in front of the bulb support yoke to minimize the projected shadow.

RECORD the bulb serial number, date, and lamphouse hours on the Xenon Bulb Record on the inside back cover of this manual. This information will be needed in the event of a bulb warranty adjustment.

IT IS RECOMMENDED to use the above-mentioned lamphouse cables when installing the xenon bulb. Anode leads supplied with bulbs are generally removable. If it is necessary to use the bulb anode lead, remove the lamphouse igniter lead, and use the clamp to secure the bulb to the support collet. Attach the bulb lead terminal to the igniter post; insulate the lead well and dress the lead away from grounded lamphouse components.

ESTABLISH A ROUTINE of periodically checking all electrical connections for tightness. Loose contacts, particularly in the DC circuit, will cause overheating and damage the xenon bulb and other components. Normal xenon bulb warranties allow **no credit** for bulb damage caused by overheating.

REFER TO THE BULB MANUFACTURER'S INSTRUCTIONS regarding bulb rotation. Most bulb manufacturers recommend rotating the bulb 180° at 50% of warranty hours. After rotating the bulb, operate at maximum allowable current for several hours, and then return to the nominal operating current.

IN THE EVENT of a bulb warranty claim, the bulb must be packaged in its original shipping container, and returned with all required warranty forms completed. Contact the dealer through whom the bulb was originally purchased for correct procedures and Return Authorizations.

IT IS A COMMON PRACTICE to replace the bulb at the expiration of its warranty period. If a xenon bulb explodes in operation, the reflector and other lamphouse components are frequently damaged. The xenon bulb manufacturer will extend *no credit* for a replacement reflector if the defective bulb is beyond warranty. Explosion-damaged reflectors are to be returned to the **bulb supplier**, NOT Strong International, unless the bulb was supplied by Strong.

OPERATION

INSTALL THE GLASS HEAT FILTER into the bracket mounted on the rear of the fadeout and douser support housing. NOTE: The *coated side* of the filter, with the XX or other marking, **must be facing the reflector**. Reach through the side door and nose opening of the lamphouse, slide the filter into the slot in the top angle bracket, and lower it into the bottom slotted bracket.

REMOVE THE PLASTIC COVER from the xenon bulb. DO NOT ignite the lamp with the cover on the bulb. Store the cover for future re-use.

CLOSE AND SECURE the lamphouse door using the tamperproof screws and special screwdriver supplied with the lamphouse. Engage the cam lock and install the security screw. The door must be completely secured to actuate the interlock switch and permit lamp ignition. Place the MODE switch in the "MAN." (manual) position.

TURN ON THE MAIN LINE SWITCH and/or circuit breaker to energize the xenon power supply. The lamphouse blowers will start and the blower interlock switches will be actuated to permit lamp ignition. The blowers will operate continuously until the xenon power supply is de-energized.

PLACE THE **LAMP SWITCH** in the "ON" position and the lamp will ignite. If ignition does not occur, or the high voltage pulse is not apparent, press the emergency ignition switch on the top of the lamphouse under the plug button. Do not hold more than **one second**; release immediately upon lamp ignition. Use of the emergency ignition switch indicates an abnormal condition; see the TROUBLESHOOTING section following.

CHECK THE READING on the lamphouse ammeter. Nominal current for the 2500 watt xenon bulb is 90 amperes. DO NOT, AT ANY TIME, exceed 100 amperes. Output current is adjusted at the power supply; see power supply manual for instructions. Operation of a new bulb is normally started at the lower end of its range (80 A.), and current is gradually increased as the bulb ages to maintain light output.

PRESS THE SMALL PUSH BUTTON SWITCH located below the ammeter to read the DC voltage at the arc. This permits immediate calculation of the power at which the lamp is operating (volts x amperes = wattage). Holding this switch in during the ignition cycle will also briefly indicate the "no load" (open circuit) DC voltage applied to the xenon bulb for ignition.

REMOVE THE REAR COVER PLATE below the instrument panel by withdrawing the two plastic plungers. This exposes the bulb positioning controls in the lamphouse back casting.

TO FOCUS THE XENON BULB and obtain the best light on the stage, the two methods outlined below are the most suitable.

MOVE THE SPOT SIZE CONTROL HANDLE (trombone) on the large lens carriage all the way forward to project the smallest spot possible; place the iris, masking shutters (choppers) and the fadeout douser blades in their full open positions. Project a spot to a wall or similar flat perpendicular surface opposite the spotlight position.

THE CENTER SECTION of the bulb positioning controls is a threaded member that focuses the bulb in relation to the reflector. Turning this adjustment moves the bulb in only one plane, into or away from the reflector. Turning this section clockwise moves the bulb away from the reflector. The small knurled screw to the left of this section can be tightened to lock the focusing mechanism after the following procedures have been completed.

THE LARGE THUMB SCREWS, on either side of the focusing control, lock the horizontal and vertical adjustment mechanism in position.

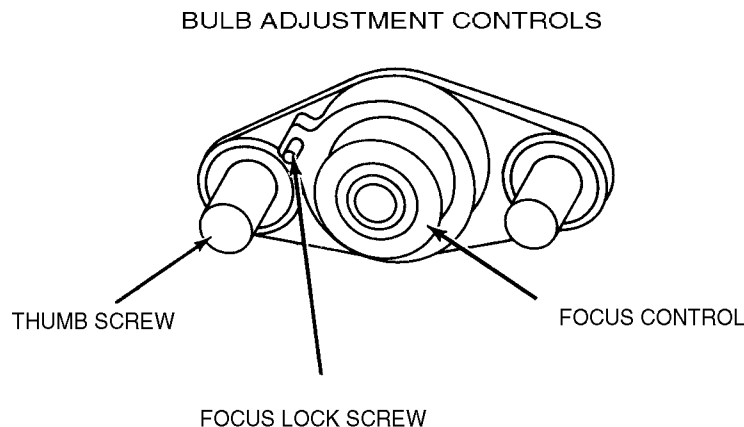

TURN THE CENTER FOCUSING SECTION of the bulb positioning control counterclockwise until a small black spot is projected onto the wall. It may be best to run this adjustment both directions to permit positive identification of the spot.

LOOSEN THE TWO THUMB SCREWS, one on either side of the center focusing section, just enough to permit manual movement of the complete assembly. The bulb positioning control will now move around these two thumb screws, and as this control is shifted, the smooth shadow of the bulb electrode can be seen extending beyond the projected center hole in the reflector. The shadow of the electrode (black spot) must be centered in the projected hole of the reflector (shaded, less dense dark area).

MOVE THE CONTROL SECTION around the two screws until the black spot is as round as possible to project. It may be necessary to again turn the focus control to project a sharply defined black spot.

AFTER THE BLACK SPOT is as even around the outside as possible to project, and appears centered in the shaded reflector center hole, tighten the two large thumb screws to lock the position of the mechanism. Turn the center focus control to obtain the brightest light with the best light distribution. Rotate the lens spot focus control knob, located at the extreme front of the lens mechanism, to obtain the sharpest edge possible on the projected spot.

THE SECOND METHOD of focusing the xenon bulb is to project the spot to the stage, and working with the above lamphouse controls, adjust these controls to obtain a "hot spot" on the projected spot. Then center this "hot spot" on the projected light by moving the entire control section around the two thumb screws. Once this "hot spot" is centered in the projected light, lock the control in position with the two thumb screws and turn the center section to obtain a spot with an even distribution of light. Rotate the lens spot focus control knob to obtain a sharp edge on the projected spot.

THESE ADJUSTMENTS should not be disturbed until it is necessary to replace the xenon bulb. At that time, the procedure on obtaining a smooth, round black spot, or "hot spot," may have to be repeated. Replace the cover plate over the bulb positioning controls.

BECAUSE OF NORMAL BULB AGING, and manufacturing tolerances between individual xenon bulbs, it may be necessary to operate lamps at slightly higher or lower current settings to maintain uniform light output when two or more spotlights are used in one installation. This entails a slight current output adjustment at the xenon power supplies. See the power supply manual.

TO EXTINGUISH the arc, place the LAMP switch on the instrument panel to "OFF." The lamphouse blowers will continue to operate until the xenon power supply is de-energized. Allow the blowers to operate for ten minutes before turning off the power supply; a forced-air bulb cooling cycle is *required* by all bulb manufacturers.

DAILY OPERATION in the "Manual" mode requires only that the xenon power supply be energized, the MODE switch be left in the "MAN." position, and the lamp switched ON and OFF by means of the LAMP switch. No bulb alignment or "warm up" are necessary. Always allow for the ten minute bulb cooling cycle.

OPERATION IN THE "AUTO" MODE is intended for use only if the spotlight is to be used as a fixed spot without an operator at the equipment. Place the MODE switch in the "AUTO" position, and the LAMP switch to "ON." The lamp will ignite when a sustained dry contact is made between the automation leads 3 and 6, and extinguish when the contact is opened. See the INSTALLATION DIAGRAM in the power supply manual. The lamphouse blowers will operate until the xenon power supply is de-energized; allow for ten minutes bulb cooling.

BEFORE OPENING the lamphouse enclosure for servicing, allow the blowers to operate for twenty minutes, or until the bulb has cooled to room temperature.

HANDLING THE SPOTLIGHT

GENERALLY THE BEST POSITION for the operator to stand is near the center of the spotlight on the right side. The angle of tilt, the size of the porthole, and the layout of the spotlight position may dictate another location.

EACH OPERATOR will, after a few minutes of operation, generally develop his own system and position for most convenient operation.

THE HORIZONTAL SWING and vertical tilt are individually adjustable to give the desired degree of friction to suit the operator. The locking clamps are located on the right side of the yoke assembly.

THE EASE with which the spot size control handle ("trombone") can be operated may be adjusted by means of the nylon friction brake screw in the outrigger of the large lens carriage casting. To access this adjustment, open the color boomerang and remove the gel frames. Slide the large lens carriage to the extreme rear position. Reach through the boomerang housing and loosen the nylon friction screw locknut. Turn the nylon friction screw clockwise to increase drag, or counterclockwise to relieve. Tighten the locknut after the desired adjustment is reached.

OPERATION OF OPTICAL SYSTEM

THE IRIS CONTROL is the front lever which projects through the top of the optical system housing. When this lever is to the left (as viewed from the rear of the unit), the largest aperture is provided. Smaller apertures are obtained as the lever is moved to the right.

THE SPOT SIZE CONTROL HANDLE is located on the right hand side of the optical system just above the base rail. A variation of spot sizes from full flood to small spot can be obtained by moving the spot size control handle from one extreme to the other. Beam intensity is increased by this optical system when reducing from flood to spot, and maximum intensity is reached when the spot size control handle is in the extreme forward position.

THE MAXIMUM FLOOD SPOT is obtained with the iris control lever to the left (away from operating side) for the largest aperture and with the spot size control handle moved as far to the rear as possible.

SMALLER SIZED SPOTS are projected as the spot size control handle is moved forward. Most of the spot sizes needed will be produced with the iris in its maximum open position.

FOR A "HEAD SPOT," or any spot smaller than can be obtained with the spot size control handle in its extreme forward position, shift the iris control lever to the right (toward operating side) for a smaller aperture. The iris control lever should always be returned to its extreme left position before the spot size control handle is again moved to obtain larger spots.

THE MASKING SHUTTER (chopper) lever is the middle lever projecting through the top of the optical system housing. The masking shutter blades are operated by this lever to shape the projected spot to a rectangle, strip spot, or dousing.

THE DISENGAGED POSITION of the masking shutter lever is to the extreme right (toward operating side) and varying degrees of masking to complete cutoff are obtained by moving the lever to the left (away from operating side).

THE ANGLE of the masking shutter blades can be adjusted to compensate for the horizontal projection angle. Remove the color boomerang and optical system housing, and loosen the screws holding each of the masking shutter blades enough to allow adjustments. Ignite the bulb and adjust the angle of the *bottom* blade by tapping with a screwdriver so its projected edge lies parallel to the footlights. Tighten the screw. Operate the masking shutter lever to close the blades. Adjust the upper blade to close in line with the bottom blade and tighten the screw.

THE FADEOUT MECHANISM AND DOUSER CONTROL is the rear lever projecting through the top of the optical system cover. This lever controls the intensity of light from complete fadeout when the lever is to the left, to full intensity when the lever is to the right.

THE SPOT FOCUSING CONTROL KNOB is located on the operating side of the optical system at the forward end above the base rail. This control is used to adjust the optical system for the length of throw. When making an adjustment, rotate the spot focusing control knob until the sharpest edge is obtained on the projected spot.

OPERATION OF COLOR BOOMERANG

THE COLOR BOOMERANG is equipped with six color holders and an ultraviolet filter. Additional filter holders can be supplied by an authorized Strong International Dealer.

TO OPERATE INDIVIDUAL COLOR FILTERS, lower the desired filter selector lever. A rocker catch located in the color disc housing holds the filter in position.

TO RELEASE A COLOR, push the filter release button or engage another color, thus releasing the previous color automatically.

TO REPLACE A FILTER HOLDER, open the hinged top of the color disc housing and lift out the desired filter holder.

HIGH TEMPERATURE FILTERS (RoscoLux® or equivalent) cut to nine inch diameter are required, and are secured in the filter holders with paper fasteners.

NOTE: WHEN PLACING COLOR FILTERS in the boomerang, the *less* dense colors (pink, amber) should be placed in the holders toward the **rear** of the boomerang (toward arc), and those of *greater* density (red, green) should be placed in the holders toward the **front** of the boomerang (away from the arc).

COLOR TEMPERATURE REDUCTION FILTERS, required for use with television and videotape, are available from theatrical supply dealers.

MAINTENANCE

THE XENON GLADIATOR II SPOTLIGHT requires very little maintenance to keep it in good working order.

THE REFLECTOR should be cleaned periodically with a soft, clean, lint-free cloth to remove dust from the reflecting surface. If excessively soiled, the reflector may be cleaned with Windex® or an equivalent glass cleaner. DO NOT use abrasive cleaners of any kind. Clean the heat filter glass; replace with the coated surface toward the lamphouse.

CHECK ALL ELECTRICAL CONNECTIONS for tightness on a regular basis. Loose connections, particularly in the DC circuit, may cause premature bulb failure and damage lamphouse components.

LUBRICATE the bulb seal blower and the lens blower with two or three drops of non-detergent oil once every six months. The exhaust blower is permanently lubricated.

THE XENON BULB should be checked occasionally for the presence of dust or foreign materials. If necessary, clean the quartz envelope of the bulb with alcohol, and wipe dry with a clean, lint-free cloth. Observe all safety procedures when working with the exposed bulb.

THE INSIDE OF THE LAMPHOUSE and the blower squirrelcages should be cleaned periodically, depending on the dust conditions at each installation. Keep the blower inlet and outlet grilles clean to permit free air flow. Clean the actuator arms of the air flow switches to prevent dust build-up.

THE LENS SYSTEM should be kept clean to prevent any light reduction in the projected spot. Tighten the horizontal swing and vertical tilt locking clamps. Remove the color gels to reach and clean the back surface of the large lens. Remove the cover casting over the fadeout, chopper, and iris controls to remove the small projection lens which is held in place with a large spring-type retainer ring at the front of the lens barrel.

CLEAN THE PROJECTION LENS and large lens with with any cleaner approved for use on coated projection lenses. Replace the projection lens with the end with the FL marking ring toward the iris; secure with the retainer ring.

BEFORE TRANSPORTING the spotlight, remove the xenon bulb from the lamphouse. Place the bulb in its plastic cover and original shipping container.

LAMPHOUSE SCHEMATIC

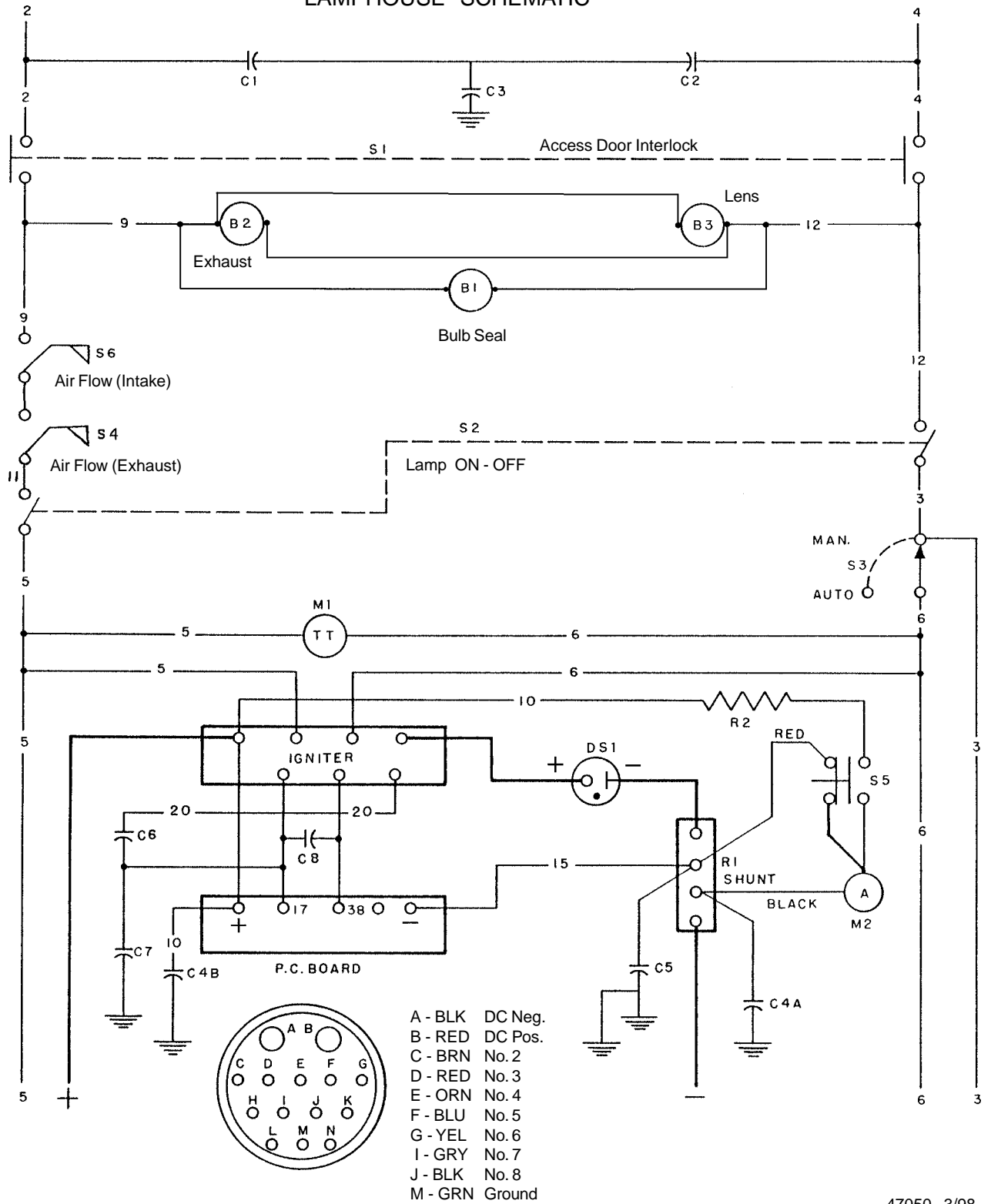

47050 - 3/98

PARTS LIST
Lamphouse Schematic

Ref.		
<u>Desig.</u>	<u>Part No.</u>	<u>Description</u>
B1	39938	Bulb Seal Blower Assembly, 115 V.AC, 50/60 Hz.
-	21-21015	Fuse, 1.5A. (F1)
B2	71220	Exhaust Blower, 115 V.AC, 50/60 Hz.
B3	47944	Lens Cooling Blower, 115 V.AC, 50/60 Hz.
C1,2	76132	Capacitor, .005 μ f, 600WVDC *
C3	76133	Capacitor, .01 μ f, 400 WVDC *
C4A, 4B	80177	Capacitor, 1.0+1.0 μ f, 600 WVDC
C5	81947	Capacitor, .01 μ f, 500 WVDC
C6,7	88263	Capacitor, .05 μ f, 600 V.DC
C8	39956	Capacitor, .05 μ f, 1200 V.DC
DS1	-	Xenon Bulb
M1	39976	Elapsed Time Meter, 60 Hz.
-	39974	Elapsed Time Meter, 50 Hz.
M2	65142	Ammeter, 0-150 A.
R1	82167	Shunt, 150 A. 50 mV.
R2	39151	Resistor, 150k Ohm, ½ Watt (Order 21-46059)
S1	80168	Door Interlock Switch
S2	81275	LAMP Switch, Rocker Type
S3	81276	MODE Switch, Rocker Type
S4	78133	Air Flow Switch, Exhaust
-	81545	Air Vane Actuator, Exhaust Switch
S5	72275	VOLTAGE Switch, Pushbutton
S6	85109	Air Flow Switch, Intake Blower
-	39949A	Igniter Assembly, Gladiator
-	40913	Igniter Printed Circuit Board Assembly
-	39939	MS Connector & Interconnect Cable Assembly
-	88318	MS Connector, 14 Pin Male
*	39933	RF Suppressor Assembly (C1, C2, C3)

PRINCIPLE OF IGNITER OPERATION

THE IGNITER is energized through the 115 V.AC control circuit when the LAMP “ON-OFF” switch (S2) is depressed and all interlocks and air flow switches are closed.

CAUTION: Do not use the Emergency Ignition switch (S102) in the igniter until it is determined that the polarity of the xenon bulb is correct. Use of the S102 switch bypasses the polarity sensing diode (CR201) on the igniter printed circuit board; if polarity is not correct, the bulb will be seriously damaged or destroyed. **No credit** is allowed on bulbs damaged by reversed polarity.

THE IGNITER supplies a high RF voltage pulse to the bulb, together with the high “No Load” DC voltage from the xenon power supply, to ignite the xenon bulb. After the arc is sustained, the AC circuit in the igniter is interrupted by the opening of K201 relay contacts on the signal of the timer circuit on the PC board. The DC output of the xenon power supply is automatically lowered to the power level required to maintain the arc. The DC power to the bulb is dependent upon the bulb characteristics and the setting of the output of the xenon power supply.

DC VOLTAGE is applied to the printed circuit board from the xenon power supply, energizing the 12 V.DC coil and closing the contacts of K201 relay, completing the AC circuit through the igniter to the T102 high voltage (10 kV.) transformer. High voltage boost capacitor C107 is charged to a voltage sufficient to cause breakdown across the E101 spark gap. Approximately 35 kV. is supplied to the xenon bulb for ignition.

S101 is the igniter cover interlock switch and S102 is the Emergency Ignition switch, which is a bypass for the K201 relay contacts and CR201 polarity sensing diode on the PC board. Components C101, 102, and 103 function as RF bypass capacitors on the igniter. The C108 capacitor serves as a coupling capacitor to the current coil.

THE PC BOARD operates on DC voltage from the xenon power supply. Capacitor C201 across the positive #10 and negative #15 is an RF suppression capacitor. Resistor R201 and zener diodes VR201 and 202 drop the DC voltage to 12 volts for the K201 relay coil. CR201 is the polarity sensing diode. C204 is a polarized capacitor used for arc suppression at the K201 relay coil, and CR202 functions as a transient protection diode.

THE FOLLOWING COMPONENTS are parts of the timing circuit on the PC board: Timer chip U201, resistors R202, 203, and the polarized capacitor C203. The C203 capacitor functions as the timing control, and CR203 serves as the “ON” time control diode. C202 is the control voltage isolation capacitor.

IGNITER ASSEMBLY, SCHEMATIC

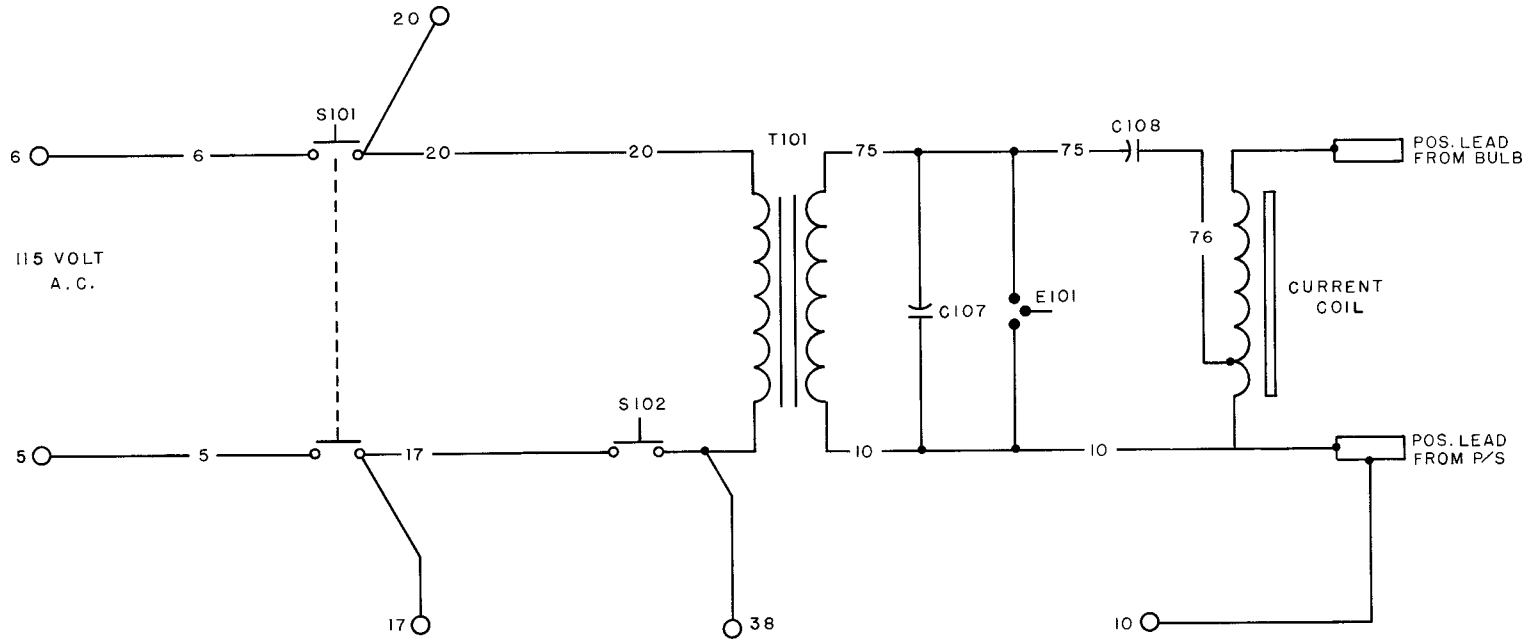

XG2/018

Ref. Desig.	Part No.	Description
C107	39110	Capacitor, 2400 pf, 20 kV.DC
C108	39110	Capacitor, 2400 pf, 20 kV.DC
E101	39923	Spark Gap Assembly
S101	80168	Cover Interlock Switch
S102	80168	Emergency Ignite Switch
T101	39937	High Voltage Transformer
-	39998	Case & Coil, Potted Assembly

XG2/019

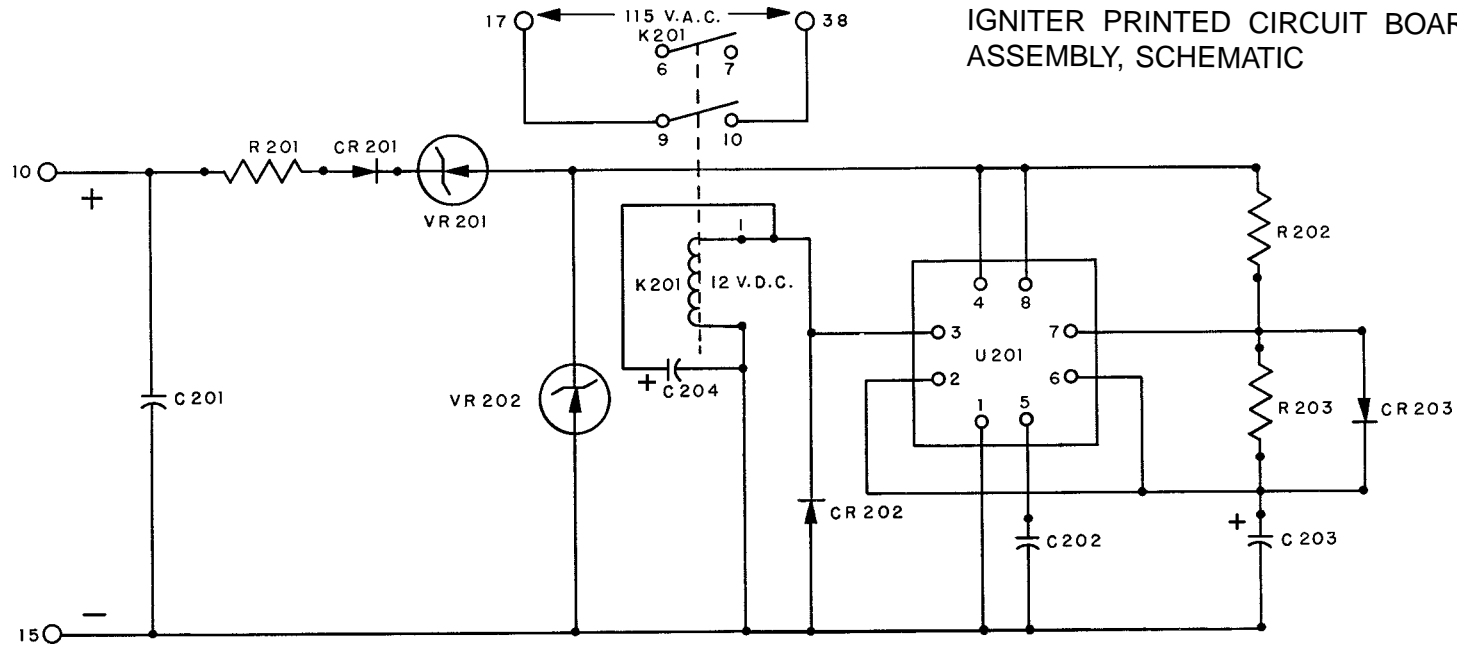

IGNITER PRINTED CIRCUIT BOARD ASSEMBLY, SCHEMATIC

WIRE MARKERS

A = 10
B = 15
C = 17
D = 38

Ref. Desig.	Part No.	Description
C201	88263	Capacitor, .05 μ f, 600 WVDC
C202	79127	Capacitor, .01 μ f, 600 WVDC
C203	39156	Capacitor, 15 μ f, 30/35 WVDC
C204	88249	Capacitor, .1 μ f, 600 WVDC
CR201	85112	Diode, 2.5 A. 1000 PRV
CR202	85112	Diode, 2.5 A. 1000 PRV
CR203	85112	Diode, 2.5 A. 1000 PRV
K201	39154	Relay, P&B R10-E1-W2S800
-	39160	Relay Socket
-	39161	Relay Hold-Down Spring
R201	39157	Resistor, 1k Ohm, 12 Watt
R202	39158	Resistor, 100k Ohm, 1/2 Watt

Ref. Desig.	Part No.	Description
R203	39159	Resistor, 200k Ohm, 1/2 Watt
U201	72185	Timer IC, Motorola MC11455P1
-	39164	IC Socket, (6) Pin
VR201	39211	Zener Diode, 1N5377A (40913*)
VR201	39167	Zener Diode, 1N5369A (39966*)
VR202	39162	Zener Diode, 1N4742
-	39145	PC Board (less Components)
*	40913	PCB Assembly, Standard
*	39966	PCB Assembly (Older Models using High Reactance Power Supply)

Assembly Number written on Component Side of PCB.

TROUBLE CHART

NORMAL OPERATION

WHEN THE SWITCH in the main AC supply line to the xenon power supply is in the ON position, and the 30 A. circuit breaker on the switching power supply is ON, the POWER light on the xenon power supply will glow. The lamphouse and power supply blowers will start. NOTE: Early model Strong Switching Power Supply blowers may not start until the LAMP switch has been closed.

OPERATION OF THE LAMPHOUSE BLOWERS will close the (2) air flow interlock switches (intake and exhaust), and if the lamphouse door is closed and correctly secured, the control circuit to the LAMP switch will be completed.

THE MODE SWITCH, located on the lamphouse instrument panel, should be in the "MAN." (Manual) position. This enables ignition control from the instrument panel, and is the normal mode of spotlight operation.

WHEN THE LAMP SWITCH is placed in the ON position, the AC control circuit in the lamphouse will energize the power supply circuitry providing DC current to the igniter and bulb. If an early model Strong switching type power supply is used, the power supply blowers will start at this point.

THERE WILL BE a distinctly audible high voltage arc ping at the igniter arc gap and across the bulb electrodes. The bulb should ignite immediately after one or two of these high voltage pulses, and the lamp current will adjust to the output setting of the xenon power supply. Multiple ignition pulses prior to bulb ignition normally indicate a low DC output setting. See xenon power supply manual. A "warm" or aged xenon bulb might also require multiple strikes.

TROUBLE SHOOTING

IF THE XENON BULB does not ignite, observe the following operational sequences for assistance in locating and isolating the trouble area.

WHEN THE FAN(S) and the indicator light on the power supply are on, the AC circuit in the power supply is trouble free up to the terminal block in the power supply.

AT THIS TIME, the lamphouse blowers should operate. If this does not occur, the trouble is in the cover interlock switch, the access panel interlock switch, the blower motor, a loose connection, a broken #2 or #4 lead, or a blown F1 seal blower fuse. Check the 1.5 A. fuse in the in-line fuseholder. CAUTION: To prevent bulb ignition when checking the AC control circuit in the lamphouse, remove lead #10 from the igniter terminal strip.

CHECK AT THIS TIME for **115 V.AC Control Voltage** at the access door interlock switch (wires 2 & 4), and the blower terminals (9 & 12). The door interlock switch must be manually actuated to energize the blowers. Replace #10 lead before proceeding.

THE VANES on the air flow switches should raise. With the MODE switch in the “MAN.” position and the LAMP switch in the “ON” position, the running time meter should start and indicate elapsed time. If this meter does not operate, check for continuity at the MODE and LAMP switches.

A DEFECTIVE RUNNING TIME METER will *not* prevent bulb ignition.

WITH THE “LAMP” SWITCH in the “ON” position, a distinct high voltage arc ping should be heard at the spark gap in the igniter, and the flash of the xenon bulb should be visible through the ammeter as a high DC voltage pulse is applied across the bulb electrodes.

IF THE HIGH VOLTAGE PING or the flash at the ammeter is not apparent, check for 115 V.AC at terminals 5 & 6 at the terminal board. If 115 V.AC is present, and terminals are tight, check then the “**No Load**” DC Voltage between the lamphouse and power supply. Remove either lead #5 or #6 at the terminal board to prevent bulb ignition and defeat the door interlock switch. Check the DC voltage across terminals #10 (-) and #15 (+). A reading of 85 V.DC should be measured if using a high reactance power supply; 120-170 V.DC if using a switching type. If this voltage is not indicated, the problem is in the leads between the lamphouse and power supply, or in the power supply boost circuit. See the trouble shooting section of the power supply manual for additional instructions. Replace lead #5 or #6 at the igniter before proceeding.

THE SWITCHING-TYPE XENON POWER SUPPLY furnished with the spotlight system includes thermal overload switches and protection circuits to prevent damage resulting from high or low input voltage. Loss of DC open circuit voltage, or an interruption of DC sustaining current, may be traced to these circuits. See the power supply manual.

IGNITER PRINTED CIRCUIT BOARD 40913 is required for use with the switching type xenon power supply. If the lamphouse is equipped with an older type, replace it with the 40913 board. If the lamphouse ignites only by means of the emergency ignition switch, replace the igniter PC board.

IF THE HIGH VOLTAGE ARC is audible at the lamphouse and the bulb does *not* flash, check for a lamphouse DC lead arcing to ground. If no ground fault is detected, replace the bulb and attempt ignition with the new bulb.

IF THE HIGH VOLTAGE ARC is audible at the lamphouse, the flash of the bulb is visible in the ammeter, but ignition of the bulb is not sustained, the problem area is in the power supply. See the trouble shooting section of the power supply manual for additional instructions.

IF THE HIGH VOLTAGE ARC is *not* audible or the flash of the bulb visible, the problem is in the igniter or igniter PC board assembly.

EXCHANGE of components (i.e. igniters, printed circuit boards) between two similar Strong Xenon Gladiators to aid in diagnosis of a problem is encouraged. This will not lead to equipment damage, and will not void equipment warranty.

XENON GLADIATOR II TROUBLESHOOTING

Bulb fails to ignite.

1. MODE switch S3 set to "AUTO." Place in "MAN." position when not employing automated or remote lamphouse operation.
2. AC power not on to lamphouse. Turn switching power supply 30 A. circuit breaker ON. If 115 V.AC not read at 2 & 4, see power supply manual.
3. Door interlock switch (S1) open. Close and secure lamphouse door.
4. Faulty interlock switch(s). Check for 115 V.AC at 9 & 12; replace switch(s) if defective.
5. Air vane switches not closing. Check for unobstructed operation; clean if required. Check continuity between "NO" and "COM;" replace if defective.
6. Faulty S2 "ON-OFF" switch. Check for voltage at 3 & 5; check for loose terminals or wiring. Replace if defective.
7. Blower fuse F1 blown. Replace as required (1.5 A. Std.).
8. Low AC source voltage actuating "brownout" protection circuit in xenon power supply.

Bulb fails to ignite; ping audible, bulb flash visible.

1. Inadequate DC output from xenon power supply. Set power supply output to correct range required for bulb wattage (90 A. nominal for 2500 watt).
2. If bulb flash is visible but faint, check for defective HV capacitor(s) in igniter. Replace if defective.
3. Faulty or expired xenon bulb. Replace as required.

Bulb fails to ignite; ping audible, no bulb flash.

1. Faulty xenon bulb. Check for cracked electrodes or darkened envelope. Replace if defective.
2. Ignition pulse shorting to ground. Inspect DC leads for burned insulation; dress leads away from grounded metal components.

No high voltage ping audible; MODE switch in "MAN." and LAMP switch in "ON."

1. Loss of AC control voltage. Check xenon power supply for tripped circuit breaker or open thermal switch. See power supply manual.
2. Little or no DC "No Load" voltage. Measure DC "No Load" voltage at 10 & 15. See power supply manual.
3. Open fuse F1 (600 V.) on switching power supply. SEE POWER SUPPLY MANUAL. Allow (20) minutes for capacitor discharge before replacing.
4. Faulty igniter printed circuit board. If lamphouse ignites immediately when emergency ignition switch is pressed, replace printed circuit board.
5. Loose spark gap connections or terminals. Repair or replace as required.
7. Faulty igniter. Check for 115 V.AC at 5 & 6; adequate DC "No Load" at 10 & 15. If present, and igniter does not fire, replace igniter.

Bulb goes out during operation.

1. Xenon power supply overheated; thermal switch open. Check power supply blower(s), air inlets and outlets unobstructed. See power supply manual.
2. Xenon bulb depressurizing. Check for envelope discoloration; replace if defective.
3. Lamphouse blower not moving adequate air. Clean; lubricate seal blower.
4. Lamphouse blower failed or obstructed. Clean dust and dirt from blower inlet grille. Check for 220 V.AC at 7 & 8; replace blower if defective.
5. Lamphouse air vane switches faulty. Check for vane actuation; adjust or replace as required.
6. Lamphouse exhaust obstructed. Clear obstruction; clean outlet grille.
7. Exhaust air flow switch reacting to backdraft. Adjust actuator to compensate for backdraft.
8. Fluctuating AC source voltage actuating brownout or spike protection circuits in xenon power supply. See power supply manual.

Power supply does not energize when actuated.

1. Door interlock switch, B1 blower, F1 blower fuse, S4 air vane switch, S2 power switch, S3 MODE switch. Check for 115 V.AC at each station; replace defective component.

SEE POWER SUPPLY TROUBLESHOOTING UNDER SAME HEADING.

Noise in theatre sound as bulb ignites.

1. Faulty RF suppression capacitor(s). Remove and test C1, C2, C3, C4A or C4B. Replace if defective.
2. Lamphouse, power supply, or sound system not properly grounded. Connect to adequate earth ground.
3. Leads between lamphouse and automation contact not shielded. Shield leads in conduit. (“AUTO” Mode applications only.)

Excessive light flicker..

1. Faulty or aged bulb. Check for cracked or sagging electrodes; replace if defective.
2. Excessive ripple in DC output. See power supply manual.
3. Arc stabilization magnet reversed. NORTH pole should point toward operator’s side. Check with compass if required.

Reduced light output.

1. Normal bulb aging. Increase output current. DO NOT EXCEED MAXIMUM CURRENT LEVEL SPECIFIED BY BULB MANUFACTURER.
2. Soiled reflector. Clean using commercial glass cleaner; USE NO ABRASIVES.
3. Soiled heat filter, projection lens, or large lens. Clean as required.

Extremely long duration between ignition pulses.

1. Low DC “no load” voltage from the xenon power supply. Check “no load” voltage; see power supply manual.
2. Defective spark gap. A “Ping” sound is normal; excessive “Hissing” is abnormal. Replace if defective.

Extremely long duration between ignition pulses (continued)

3. Low AC voltage to lamphouse. Check for 115 V.AC at 2 & 4; if below 95 volts, check stepdown transformer in xenon power supply. See power supply manual.
4. Defective timer IC chip on igniter PC board. Replace if defective.

Igniter continues to fire after bulb ignites.

1. Faulty igniter printed circuit board. Replace circuit board IMMEDIATELY to prevent bulb damage.

Color gels burning or fading prematurely.

1. Bulb focused to “hot spot.” Refocus bulb to flat field with iris fully open and spot size control handle (“trombone”) fully forward.
2. Heat filter glass reversed or peeled. Check for *coated surface toward bulb*; replace if coating peeled.
3. Reflector coating peeled. Replace if defective.

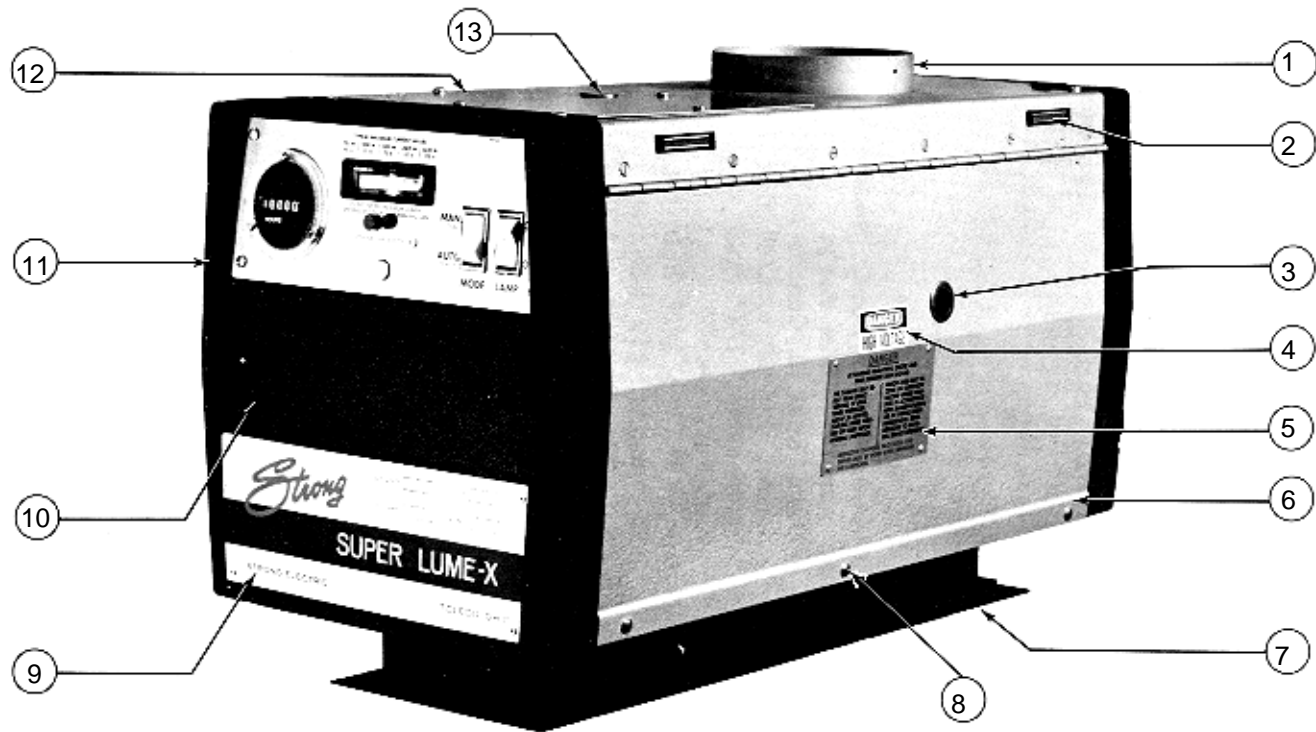

FIGURE 1

PARTS LIST

Figure 1

<u>Item</u>	<u>Part No.</u>	<u>Description</u>
1	39964	Top Cover & Door Welded Assembly
-	01307	Screw, 10-32 x 2/3" Pan Head
-	00885	Lockwasher, #10
2	39139	Magnetic Door Catch (2 req'd.)
3	48930	Arc Viewing Port
4	65353	DANGER Label
5	81282	CAUTION Label
-	01639-5	Pop Rivet, 1/8"
6	39964	Top Cover & Door Welded Assembly
7	39995	Base Adapter Assembly
-	39125	Base Plate
-	39126	Base Channel, Right
-	39127	Base Channel, Left
-	39128	Front Shim
-	00344	Screw, 10-24 x 5/16" Flat Head
-	39129	Shim, Rear & Center
-	41-51121	Screw, 1/4-20 x 5/8" Hex Head
-	00876	Lockwasher, 1/4" Split Ring
8	01736-1	Tamperproof Screw, 10-32 x 1/2" Holt Head
-	01715	Flatwasher, #10
-	01507	Tinnerman Nut, #10 (Clip-On)
-	65149A	Screwdriver (for 01736-1)
9	39219	Name & Data Plate, Super Lume-X
-	01639-2	Pop Rivet, 1/8"
10	65968	Cover Assembly, Bulb Adjust Controls
-	65140	Cover Plate
-	65166	Plunger, Black Plastic
-	65167	Grommet, Black Plastic
11	39954	Back Casting Assembly (see Fig. 3 & 4)
12	39982	Igniter Access Panel
-	01304	Screw, 8-32 x 5/16" Pan Head
-	00891A	Lockwasher, #8
13	57275	Plug Button, Emergency Ignite Switch

NOT SHOWN

71284 Cam Lock & Key, Lamphouse Access Door

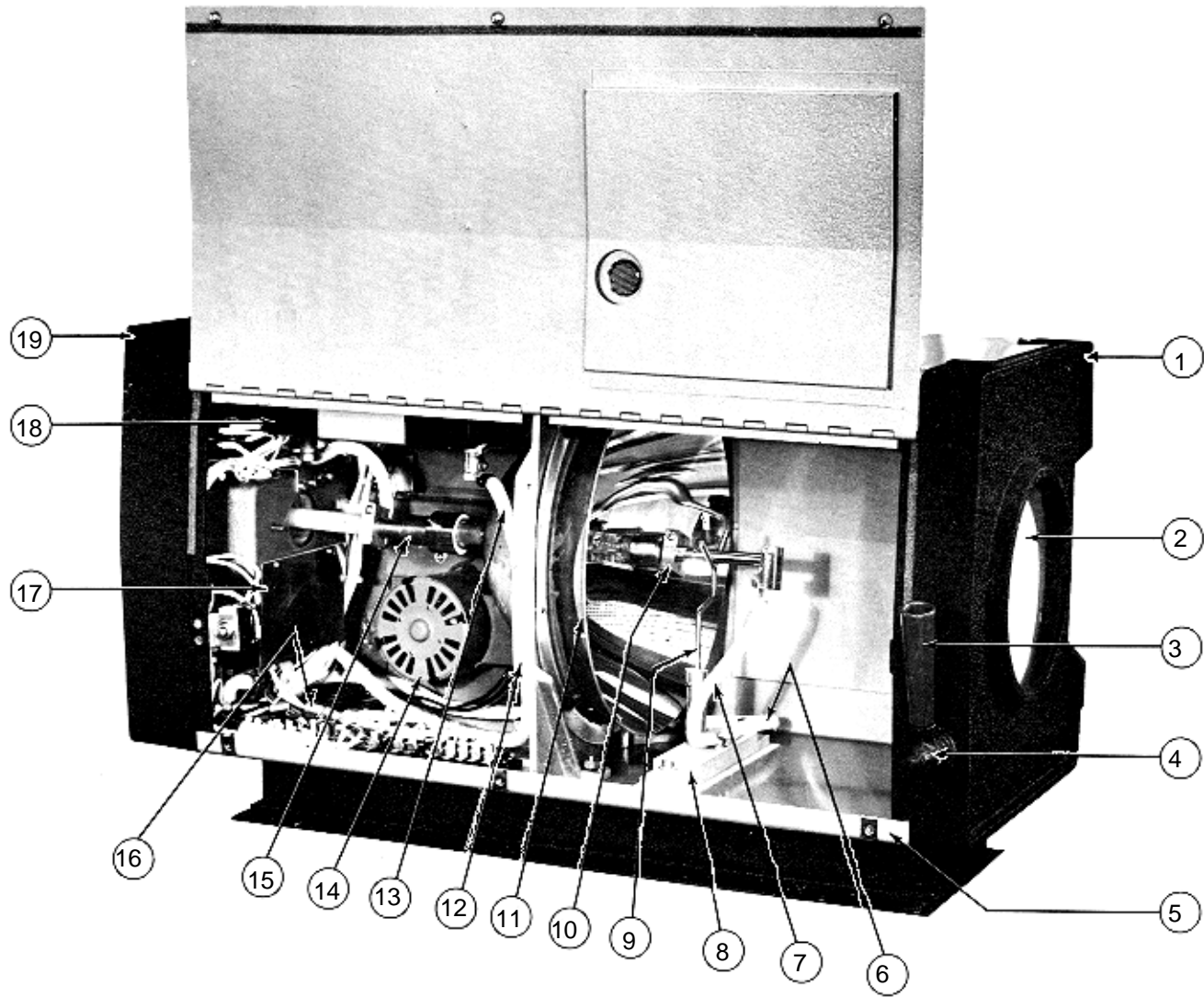

FIGURE 2

PARTS LIST

Figure 2

<u>Item</u>	<u>Part No.</u>	<u>Description</u>
1	65111	Front Casting
2	-	<i>Douser Assembly</i>
3	-	<i>not used on</i>
4	-	<i>Gladiator Lamphouse</i>
5	39972	Lamphouse Base
-	01307	Screw, 10-32 x 3/8" Pan Head
-	00885	Lockwasher, #10
-	01507	Tinnerman Nut, #10
6	65948	Lead Assembly, Shunt to Binding Post
7	39953	Negative Lead & Contact Assembly
-	00685	Screw, 1/4-20 x 3/8" Hex Head
-	00889	Lockwasher, 1/4"
8	39931	Block & Post Assembly, Front Bulb Support
-	01761	Mounting Screw, 1/4-20 x 1" Hex Head Nylon
9	39975	Bulb Support Yoke
-	01704	Spring Pin, Height Adjust
-	01721	Set Screw, 8-32 x 5/16"
10	-	Bulb Adapter <i>not required</i> in Gladiator Lamphouse
11	39978	Reflector Assembly, Potted Assembly (as shown)
11	23755	Flanged Reflector, 11" Dichroic (current production)
-	65435	Reflector Adapter Ring, Black Enamel
-	21-58001	Compression Spring, Long
-	18194	Shoulder Bolt
-	P-3055	Compression Spring, Short
-	41-51125	Ring Mounting Screw, 1/4-20 x 7/8" Hex Head
12	65114	Reflector Bulkhead Casting
-	00691	Mounting Screw, 1/4-20 x 3/4" Hex Head
-	39149	Tie Rod (to Front Casting)
-	00805	Hexnut, 1/4-20
-	39179	Arc Stabilization Magnet
-	81137	Magnet Clamp
-	39178	Mounting Plate, Magnet Clamp
13	39939	Cable Assembly, Lamphouse to Power Supply
-	88318	MS Connector, (14) Pin (not shown)
14	39938	Lamphouse Blower Assembly, 115 V.AC, 50/60 Hz.
-	85109	Air Vane Switch (S6), 60 Hz.
-	39955	Air Vane Switch (S6), 50 Hz.
-	83131	Blower Inlet Grille

PARTS LIST, Figure 2 (continued)

<u>Item</u>	<u>Part No.</u>	<u>Description</u>
15	-	Bulb Adapter <i>not required</i> in Gladiator Lamphouse
-	39194	Anode Clamp, Gladiator II
16	39933	RF Suppression Capacitor Assembly (C1,C2,C3)
17	39165	Shield, Printed Circuit Board
-	00254	Screw, 8-32 x 1/4" Fillister Head
-	00886A	Lockwasher, #8
18	39949A	Igniter Assembly (see Figure 5)
19	39954	Back Casting Assembly (See Fig. 3 & 4)

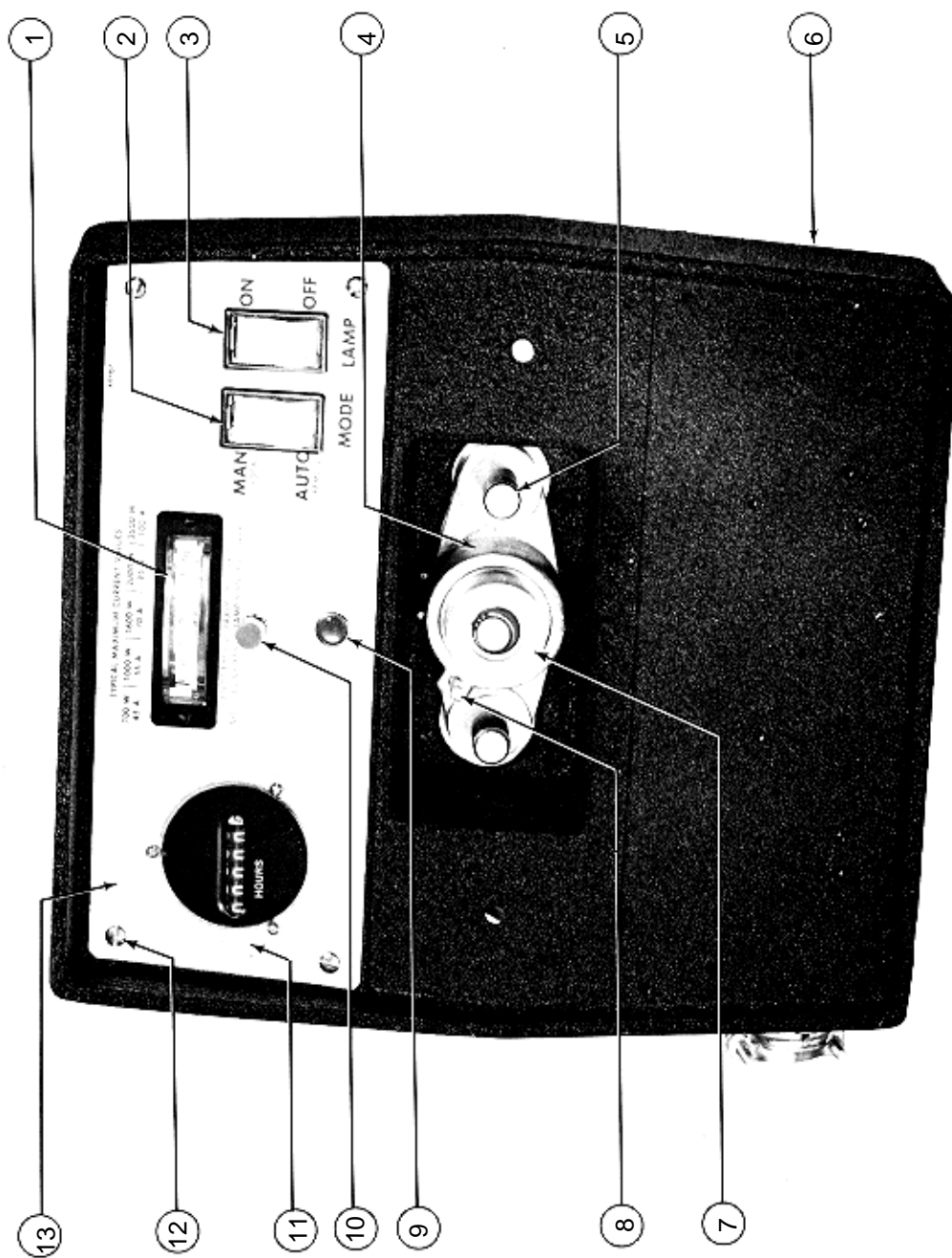

FIGURE 3

PARTS LIST

Figure 3

<u>Item</u>	<u>Part No.</u>	<u>Description</u>
1	65142	Ammeter (M2)
2	81276	MODE Switch (S3)
3	81275	LAMP Switch (S2)
4	65116	Casting, Bulb Adjust Mechanism
5	37985	Thumb Screw
-	15010	Compression Spring
-	65150	Fender Washer
6	65112	Rear Casting
7	65959	Focus Screw & Bearing Assembly
-	21-48027	Snap Ring, Bulb Collet
8	65153	Knurled Lockscrew
9	76329	Plug Button
10	39970	VOLTAGE Switch Assembly
-	72275	Switch, Pushbutton (S5)
-	39151	Resistor (R2)
-	39152	Label, "Press for Voltage"
11	39976	Elapsed Time Meter (M1), 60 Hz.
-	39974	Elapsed Time Meter, 50 Hz. (Export)
-	00953	Mounting Screw, 4-40 x 1/2" Round Head
-	01620	Hexnut, 4-40
-	01343	Lockwasher, #4
12	01304	Screw, 8-32 x 5/16" Pan Head
-	00891A	Lockwasher, #8
13	65107	Instrument Panel (less Components)

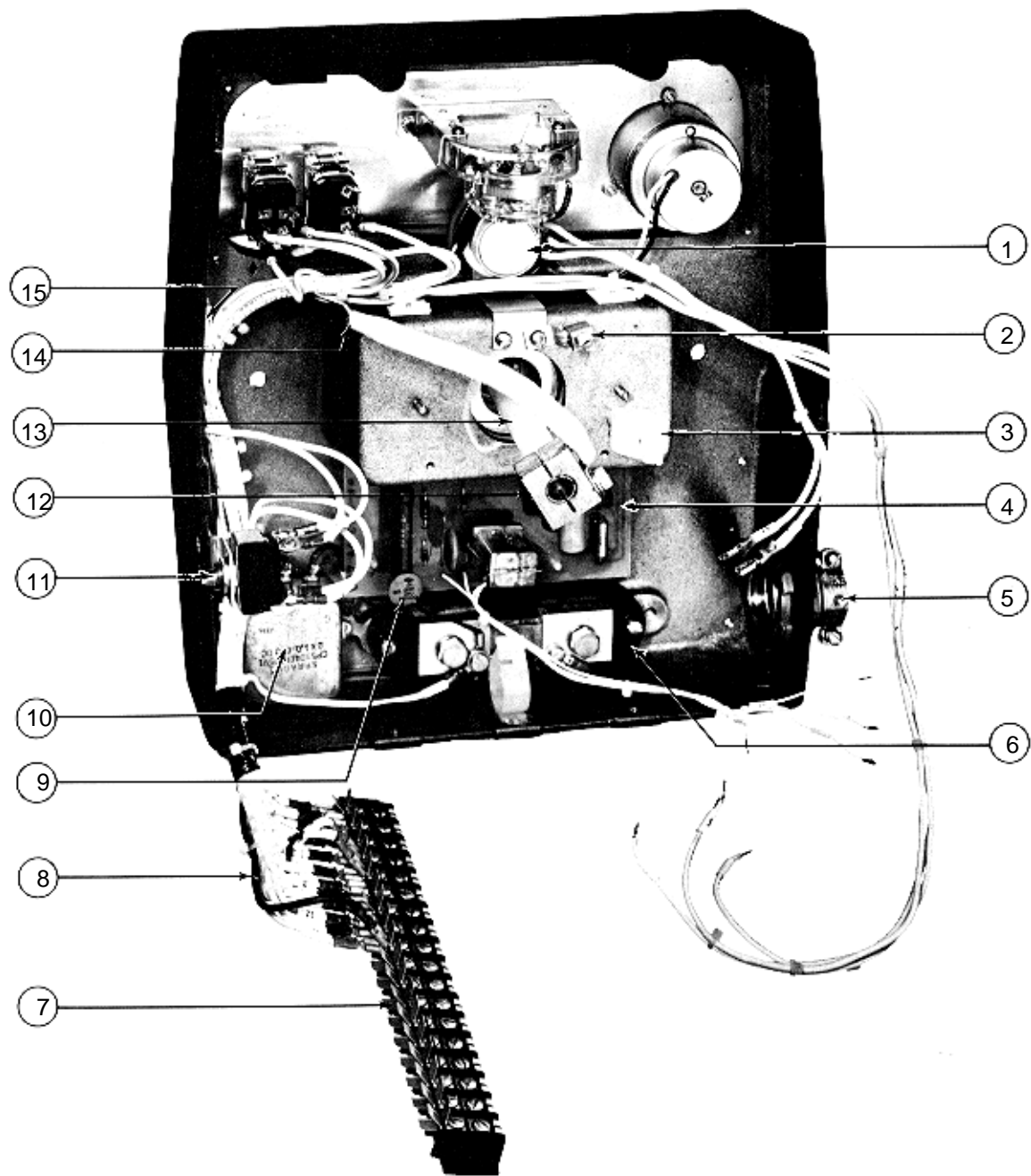

FIGURE 4

PARTS LIST

Figure 4

<u>Item</u>	<u>Part No.</u>	<u>Description</u>
1	39969	Potentiometer Assembly (early models*)
2	79131	Ground Lug
-	00255	Screw, 8-32 x 5/16" Fillister Head
-	00886	Lockwasher, #8
3	39143	Cable Clamp
4	40913	Igniter Printed Circuit Board
4	39966	Igniter Printed Circuit Board**
-	39154	Relay (K201)
-	39155	PCB Stand-Off, Nylon
5	81143	Strain Relief Cable Clamp
-	39939	Cable Assembly, Lamphouse to Power Supply
6	82167	Shunt (R1)
-	00385	Mounting Screw, 10-24 x 1/2" Fillister Head
-	00875	Lockwasher, #10 Split Ring
7	39130	Barrier Strip, (15) Terminal
-	39153	Insulation & Marker Strip
8	39921	Wire Harness Assembly (incl. Item 7)
9	81947	Capacitor Assembly (C5)
-	00377	Grounding Screw, 10-24 x 1/4" Fillister Head
-	00885	Lockwasher, #10
10	39986	Capacitor Assembly
-	80177	Capacitor (C4A)
11	80168	Door Interlock Switch
-	72178	Bracket
-	00167	Screw, 6-32 x 1/2" Flat Head
-	00892	Lockwasher, #6
-	41-35005	Hexnut, 6-32
12	39194	Anode (+) Clamp
-	01532	Clamping Screw, 8-32 x 7/8" Socket Head
13	39952	Bulb Support Collet
14	39945	Igniter Cable & Clamp Assembly
-	00685	Screw, 1/4-20 x 3/8" Hex Head
-	00899	Lockwasher, 1/4"
15	72199	Wire Tie Mount, Self-Adhesive
	*	Used with Strong Type 88000 Power Supplies only
	**	Used with High Reactance Power Supplies only

IGNITER ASSEMBLY

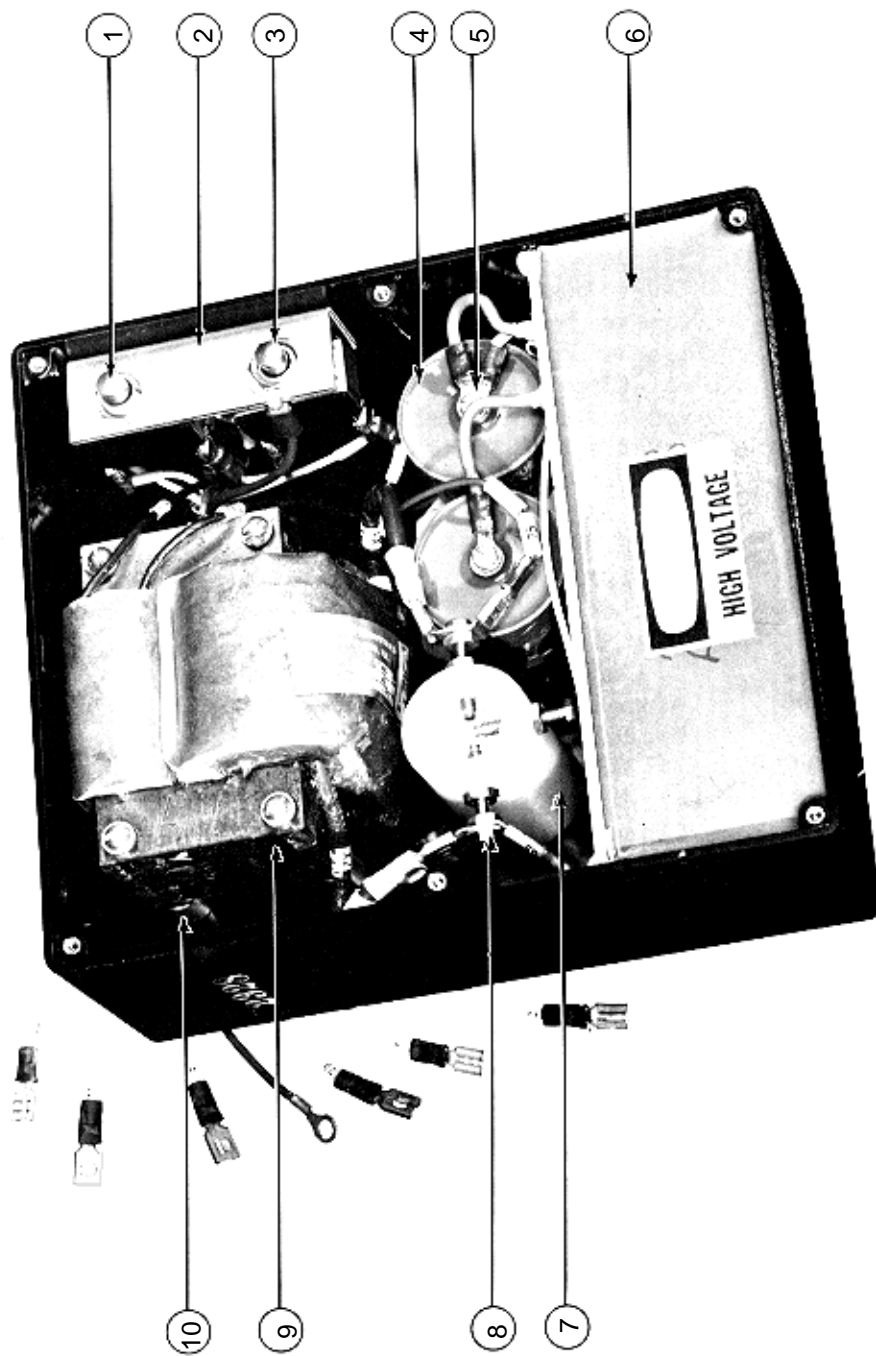

FIGURE 5

PARTS LIST

Figure 5

<u>Item</u>	<u>Part No.</u>	<u>Description</u>
1	80168	Cover Interlock Switch (S101)
2	39113	Switch Bracket
-	00343	Screw, 10-32 x 1/2" Flat Head
3	80168	Emergency Ignite Switch (S102)
4	39110	High Voltage Capacitor (C107, 108)
-	00254	Screw, 8-32 x 1/4" Fillister Head
-	00891A	Lockwasher, #8
-	39112	Capacitor Mounting Plate
-	01752	Screw, 1/4-21 x 1" Hex Head Nylon
-	01754	Hex Nut, 1/4-20 Nylon
5	01742	Screw, 8-32 x 1/4" Pan Head
-	00891A	Lockwasher, #8
6	39998	Case & Current Coil, Potted Assembly
-	65353	DANGER Label
7	39201 *	Spark Gap Body, Nylon
-	01567	Screw, 10-24 x 1/2" Pan Head
8	39107 *	Contact Screw, Tungsten
-	39109	Terminal Tab
-	00831	Flatwasher, #10 Brass
-	00795	Hexnut, 8-32
*	39923	Spark Gap Assembly (Items 7 & 8, Gapped)
9	39937	High Voltage Transformer (T102)
-	01582	Flatwasher, #8
-	00795	Hexnut, 8-32
10	39204	Transformer Spacer

NOT SHOWN

39101	Cover, Igniter Box
01305	Cover Mounting Screw, 6-32 x 1/4" Pan Head

LAMPHOUSE EXHAUST BLOWER
 Assembly No. 47935

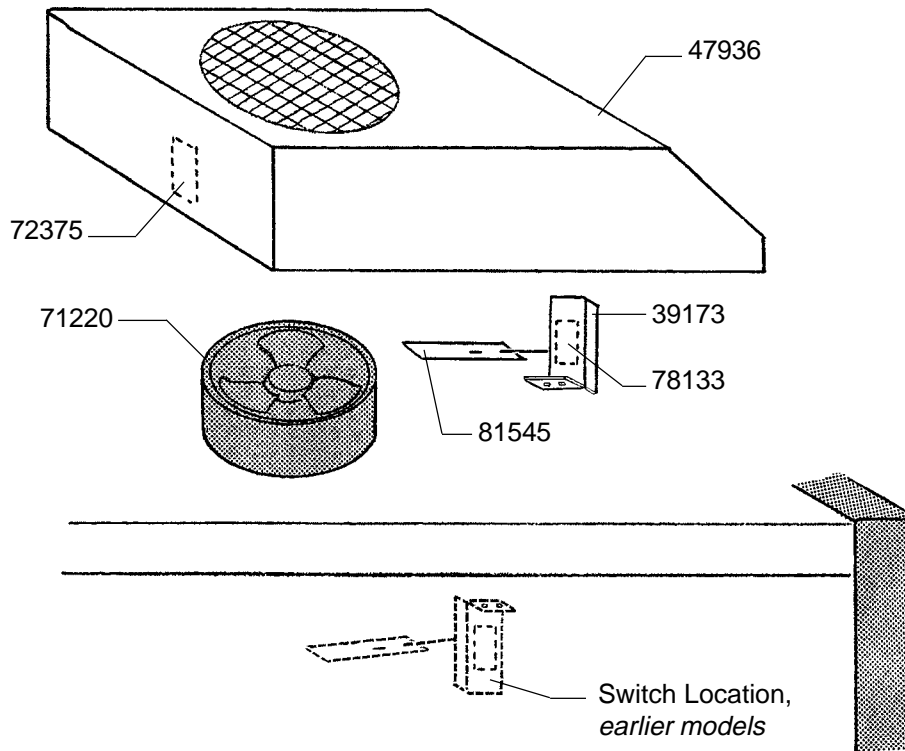

<u>Part No.</u>	<u>Description</u>
39173	Switch Bracket
47936	Blower Housing, Welded Assembly
71220	Blower (B2), 115 V.AC, 50/60 Hz.
40937	Plug & Cord Assembly
72375	Barrier Strip, (2) Terminal
78133	Air Flow Switch (S4)
81545	Actuator, Air Flow Switch

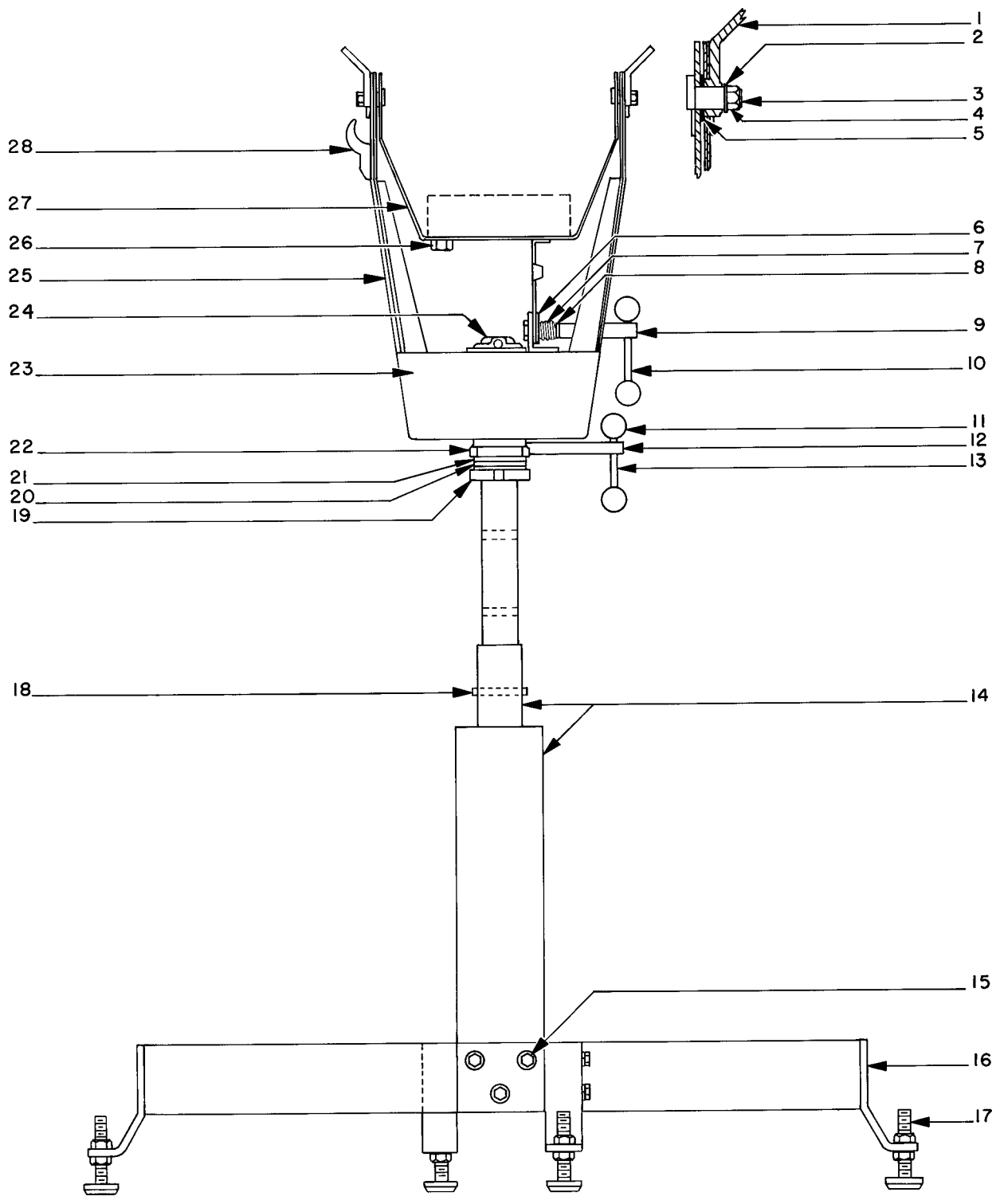

FIGURE 6

PARTS LIST

Figure 6

<u>Item</u>	<u>Part No.</u>	<u>Description</u>
1	49943	Lifting Strap
2	00854	Flatwasher, 3/8"
3	49120	Tilt Axis Bolt
4	01319	Locknut, 3/8-16 Hex
5	02411	Washer, .640" I.D. x 1-1/4" O.D.
6	49126	Clamp Plate
7	49125	Compression Spring, Tilt Clamp
8	49124	Spring Bushing
9	49223	Clamp Shaft
10	49130	Clamp Handle
11	10048A	Knob, Round Plastic
12	49290	Swivel Clamp Shaft
-	49291	Stop Plate, Horizontal Swivel
-	01523	Bolt, 3/8-16 x 2-1/2" Square Head
13	49130	Clamp Handle
14	83799	Base Column, Welded Assembly
15	83297	Mounting Bolt, Base Leg
-	00878	Lockwasher, 3/8" Split Ring
16	83797	Base Leg, Welded Assembly
-	47238	Tandem Caster, Locking (not shown)
17	49226	Leveling Foot
-	00992	Locknut, 1/2-13 Hex
18	83294A	Height Adjustment Pin
19	83794	Tube & Collar Assembly
20	83113	Needle Bearing
21	83114	Race, Needle Bearing
22	49213	Swivel Clamp Collar
-	00687	Screw, 1/4-20 x 1/2" Hex Head
-	00876	Lockwasher, 1/4" Split Ring
23	83357	Yoke Cover Plate
-	01311	Screw, 8-32 x 3/8" Pan Head
-	00891A	Lockwasher, #8
24	83112	Collar, Inner Tube
-	01759	Set Screw, 1/4-28 x 3/8" Dog Point
25	47951	Yoke Assembly
26	41-51147	Screw, 3/8-16 x 1"
-	00878	Lockwasher, 3/8"
-	41-70007	Flatwasher, 3/8"
-	41-35020	Hexnut, 3/8-16
27	47958	Saddle & Quadrant Assembly
28	83341	Cable Clamp
-	41-51121	Screw, 1/4-20 x 5/8" Hex Head

XG2/039

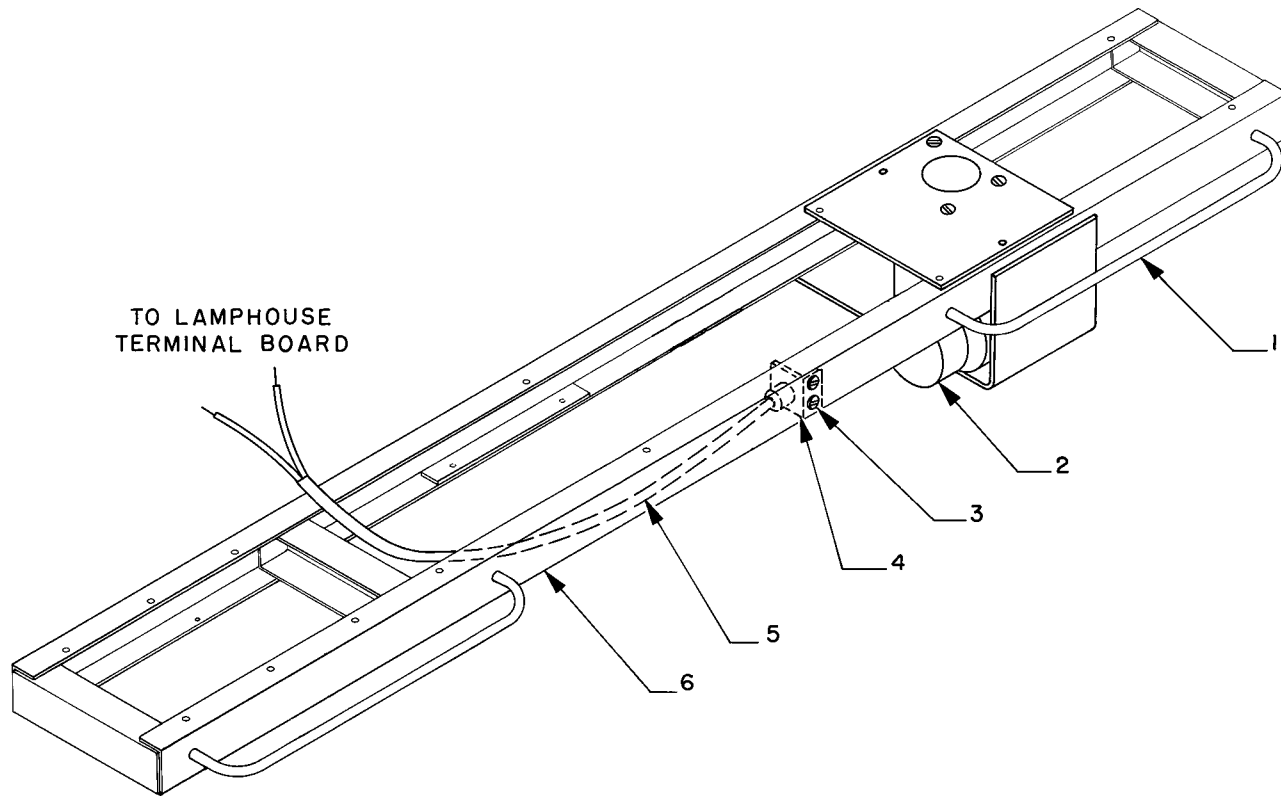

FIGURE 7

PARTS LIST

Figure 7

<u>Item</u>	<u>Part No.</u>	<u>Description</u>
1	49342	Hand Rail
-	00877	Lockwasher, 5/16" Split Ring
-	01346	Screw, 5/16-18 x 1/2" Hex Head
2	47944	Blower Assembly (B3), with Item 5
-	44191	Blower Motor & Squirrelcage, 115 V.AC
-	21-40011	Plug, (2) Pin Male
-	31-62007	Molex Pin, Male
-	21-40019	Receptacle, (2) Pin Female
-	31-62006	Molex Pin, Female
3	01311	Screw, 8-32 x 3/8" Pan Head (as req'd.)
4	47177	Receptacle Bracket (not req'd. in current units)
5	21-71066	Cable, 18/2 Type SJ (incl. with Item 2)
6	47965	Base Rail, Welded Assembly

XG2/041

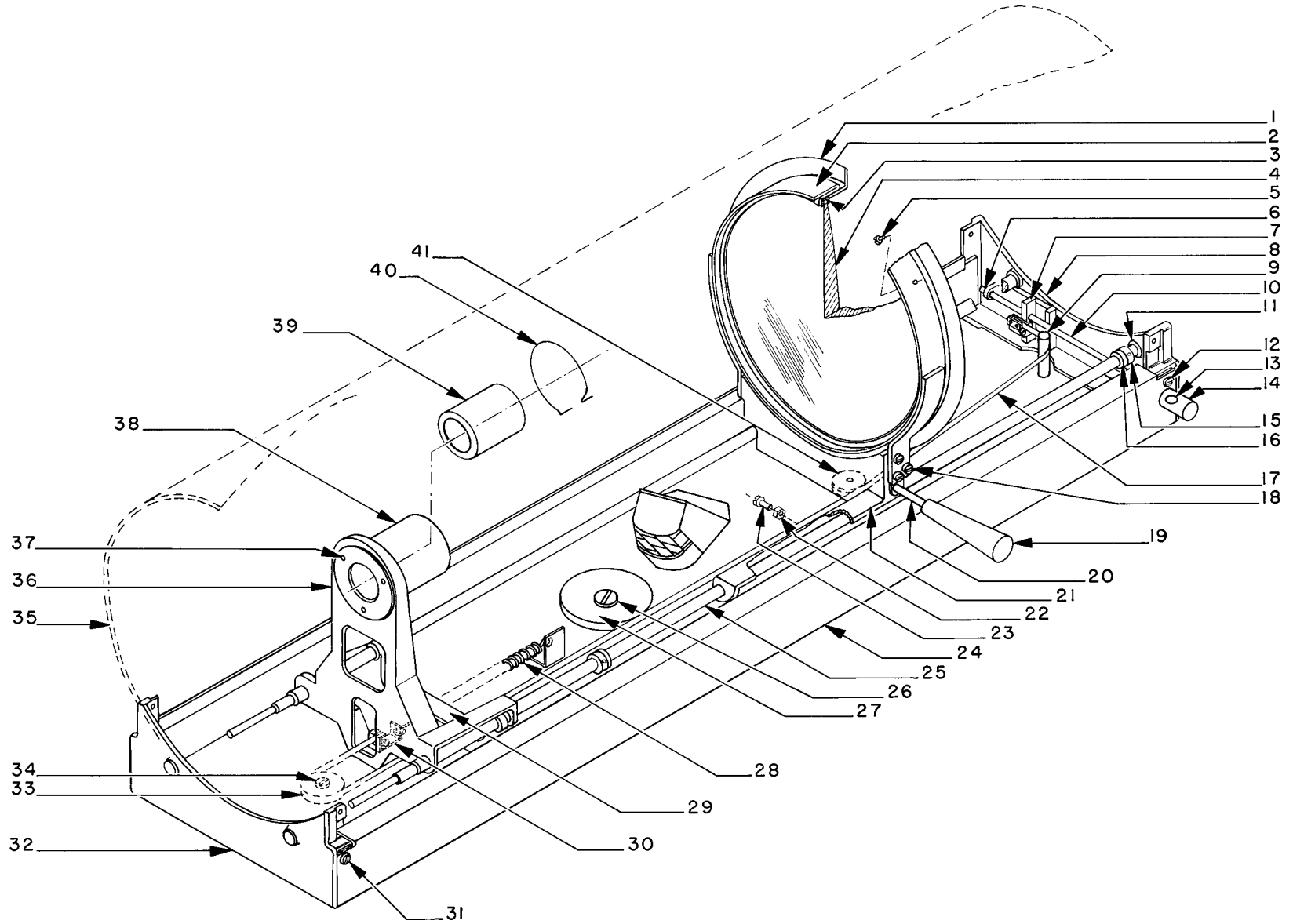

FIGURE 8

PARTS LIST

Figure 8

<u>Item</u>	<u>Part No.</u>	<u>Description</u>
1	51417	Large Lens Retainer
2	51914	Lens Ring, Welded Assembly
3	51418	Rubber Gasket, Lens Mount
4	51408	Large Lens, 11" Diameter
5	00253	Screw, 8-32 x 3/16" Fillister Head
6	00919	Cotter Pin, 1/16" x 1/2"
-	00831	Flatwasher, #10 Brass
7	51133	Adjusting Block, Lens Focus
-	00179	Screw, 6-32 x 1/4" Fillister Head
-	00892	Lockwasher, #6
8	51352	End Casting, Front
9	47207	Stud, Lens Focus Adjust
-	00541	Screw, 1/4-20 x 1/2" Pan Head
-	00889	Lockwasher, 1/4"
10	51454	Adjusting Screw, Lens Focus
11	48127	Retaining Ring
12	00541	Screw, 1/4-20 x 1/2" Pan Head
-	00889	Lockwasher, 1/4"
13	41-51170	Set Screw, Focus Adjust Knob
14	51168	Focus Adjust Knob
15	51114	Stop Collar, Slide Rod
-	00720	Set Screw, 10-32 x 3/16"
16	51479	Rubber Bumper
17	51910	Ribbon Assembly, Lens Focus
18	00381	Screw, 10-24 x 3/8" Fillister Head
-	00894	Lockwasher, #10 Split Ring
19	51509	Handle, Red Plastic
20	51441	Handle Shaft
-	51428	Retaining Ring
21	51350	Support Casting, Large Lens Carriage
22	01754	Locknut, 1/4-20 Hex Nylon
23	01752	Friction Brake Screw, 1/4-20 x 1" Hex Head Nylon
24	47968	Base Pan, Welded Assembly
25	51453	Slide Rod (Left & Right)
26	51160	Pulley Stud
-	00830	Flatwasher, #8 Brass
27	47210	Large Pulley

PARTS LIST, Figure 8 (continued)

<u>Item</u>	<u>Part No.</u>	<u>Description</u>
28	51162	Expansion Spring, Ribbon Tension
29	51354	Support Bracket, Slide Rods
-	00541	Screw, 1/4-20 x 1/2" Pan Head
-	00889	Lockwasher, 1/4"
30	51120	Retaining Clip, Spring & Ribbon
-	01304	Screw, 8-32 x 5/16" Pan Head
-	00891A	Lockwasher, #8
-	00919	Cotter Pin, 1/16" x 1/2"
31	00541	Screw, 1/4-20 x 1/2" Pan Head
-	00889	Lockwasher, 1/4"
32	51353	End Casting, Rear
33	83163	Small Pulley
34	51160	Pulley Stud
-	00830	Flatwasher, #8 Brass
35	47967	Lens Mechanism Housing, Welded Assembly
-	23059A	STRONG Insignia
-	47168	GLADIATOR Insignia
-	45237	Insignia, Roman Numeral "II"
-	47962	Rubber Light Baffle, for Item 20 Shaft
36	83160	Support Casting, Projection Lens
37	00237	Screw, 8-32 x 3/8" Flat Head
38	83144	Mounting Tube, Projection Lens
39	44239	Projection Lens, Compound
40	83155	Retaining Ring, Projection Lens
41	47211	Pulley, Large Lens Carriage

XG2/044

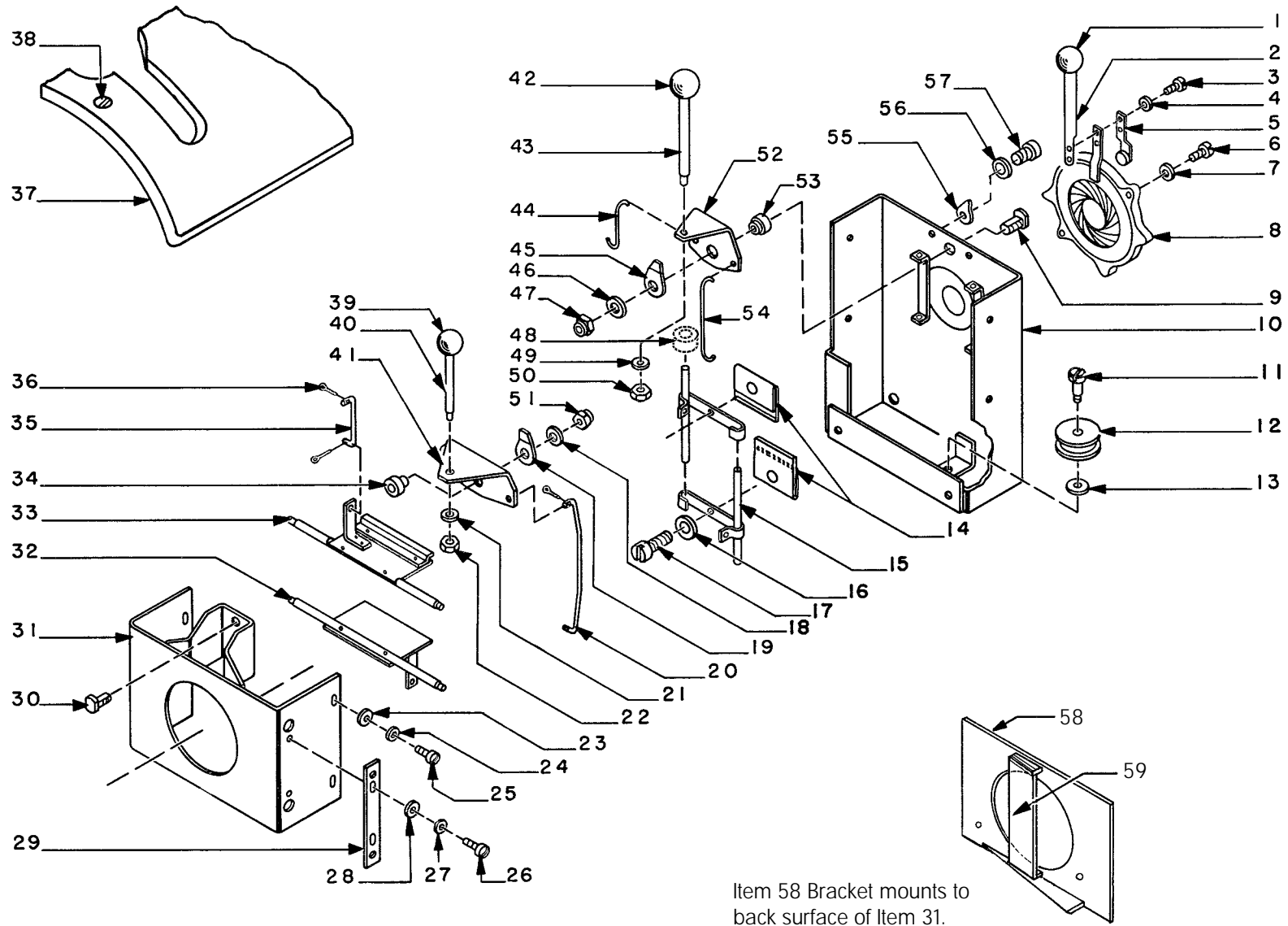

Item 58 Bracket mounts to back surface of Item 31.

FIGURE 9

PARTS LIST

Figure 9

<u>Item</u>	<u>Part No.</u>	<u>Description</u>
1	10048A	Knob, Red Plastic
2	51451	Iris Shaft
3	00180	Screw, 6-32 x 5/16" Fillister Head
4	00892	Lockwasher, #6
5	51978	Friction Spring & Button
-	51229	Friction Pad
6	00184	Screw, 6-32 x 5/8" Fillister Head
7	00862	Lockwasher, #6
8	51979	Iris (as shown; see Fig. 9A for current configuration)
-	83181	Plate, 51979 Iris
-	83182	Retaining Clip, 51979 Iris
9	51226	Pivot Stud
10	83773	Aperture Support Plate
11	51160	Pulley Stud
12	83163	Large Pulley
13	00830	Flatwasher, #8 Brass
14	47191	Masking Blade
15	47982	Slide Assembly, Masking Blade
16	00886A	Lockwasher, #8 Split Ring
17	00253A	Screw, 8-32 x 3/16" Fillister Head
18	00853	Flatwasher, 1/4"
19	51156	Friction Plate
20	83134	Fadeout Pull Rod, Long
21	00876	Lockwasher, 1/4" Split Ring
22	00805	Hexnut, 1/4-20
23	00831	Flatwasher, #10 Brass
24	01344	Lockwasher, #10
25	00378	Screw, 10-32 x 1/4" Fillister Head
26	00378	Screw, 10-32 x 1/4" Fillister Head
27	01344	Lockwasher, #10
28	00831	Flatwasher, #10 Brass
29	83351	Retaining Strip, Fadeout Bracket
30	51226	Pivot Stud
31	83890	Fadeout Support Assembly
32	83892	Fadeout Blade, Lower
33	83891	Fadeout Blade, Upper
34	51153	Spacer Bushing

PARTS LIST, Figure 9 (continued)

<u>Item</u>	<u>Part No.</u>	<u>Description</u>
35	83133	Fadeout Pull Rod, Short
36	01704	Spring Pin
37	51357	Cover Plate Casting
38	00541	Screw, 1/4-20 x 1/2" Pan Head
39	10048A	Knob, Red Plastic
40	51155	Control Lever, Fadeout Mechanism
41	83143	Fadeout Lever Bracket
42	10048A	Knob, Red Plastic
43	51452	Control Lever, Masking Blades
44	51498	Masking Blade Pull Rod, Short
45	51156	Friction Plate
46	00853	Flatwasher, 5/16"
47	01406	Hexnut, 5/16-18 FlexLock
48	MAL-64	Spacer (early models only)
49	00876	Lockwasher, 1/4" Split Ring
-	00852	Flatwasher, 1/4"
50	00805	Hexnut, 1/4-20
51	01406	Hexnut, 5/16-18 FlexLock
52	48406	Bracket, Masking Blade Control Lever
53	51153	Spacer Bushing
54	51497	Masking Blade Pull Rod, Long
55	47170	Stop Bracket, Iris Lever
56	00891	Lockwasher, #8 Split Ring
57	00254	Screw, 8-32 x 1/4" Fillister Head
58	47966	Mounting Bracket, Heat Filter Glass
-	01307	Mounting Screw, 10-32 x 3/8" Pan Head
-	01344	Lockwasher, #10
59	65122A	Heat Filter Glass, Coated

ASSEMBLIES

83788	Aperture Plate, Masking Blades, and Iris (Items 1-17, 42-50, & 52-57)
83790	Fadeout Mechanism and Blades (Items 18-36, 39-41, & 51)

FIGURE 9A

<u>Part No.</u>	<u>Description</u>
01306	Screw, 6-32 x 5/16"
21-70029	Spring Washer
24369	Bell Crank
24372	Adapter Ring
24374	Iris
25034	Iris Clamp
25035	Link with Pins
41-51252	Screw, 8-32 x 5/8"
41-50325	Screw, 6-32 x 3/8"
41-51530	Shoulder Bolt
51451	Iris Control Handle

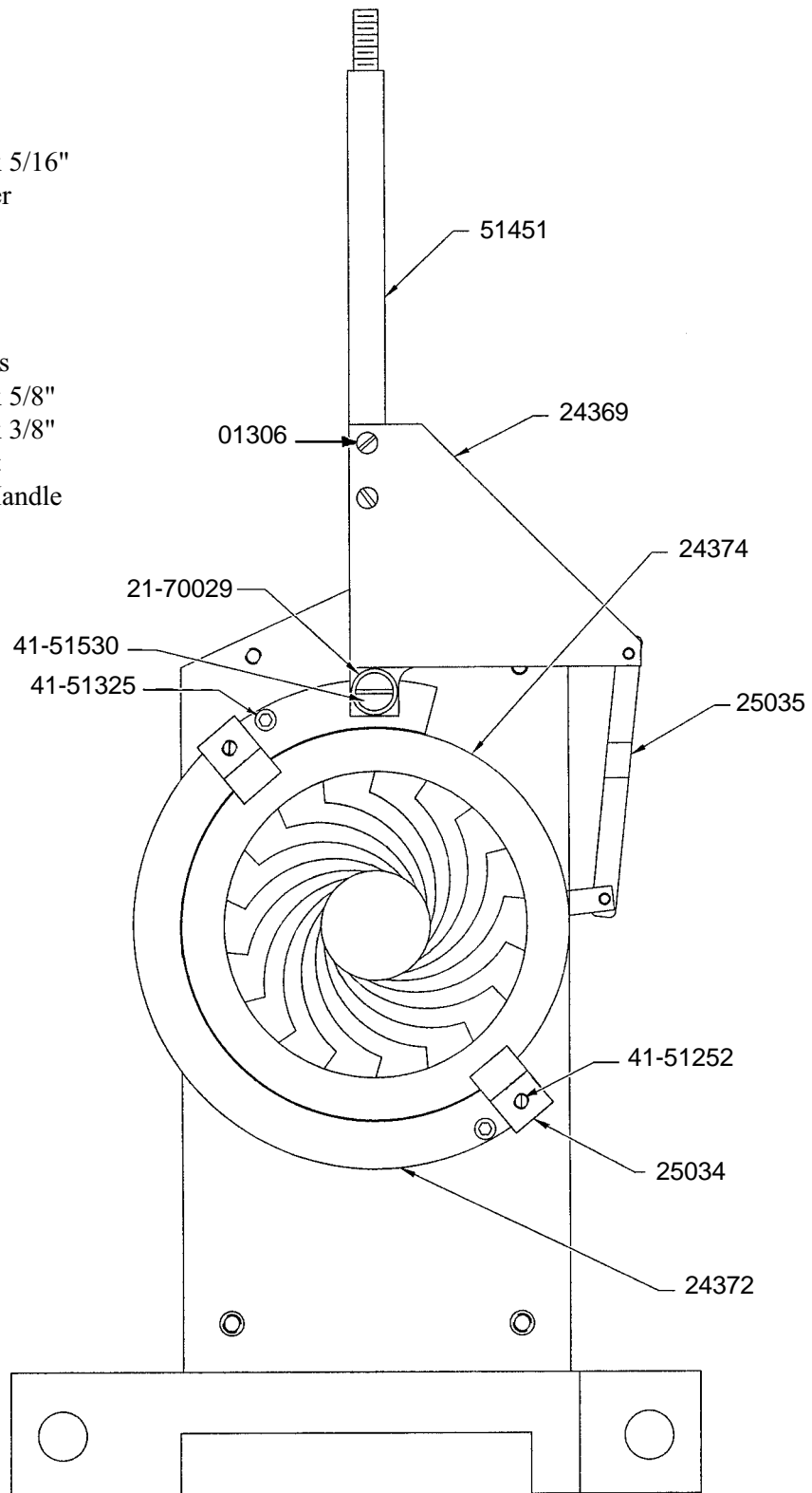

XG2/048

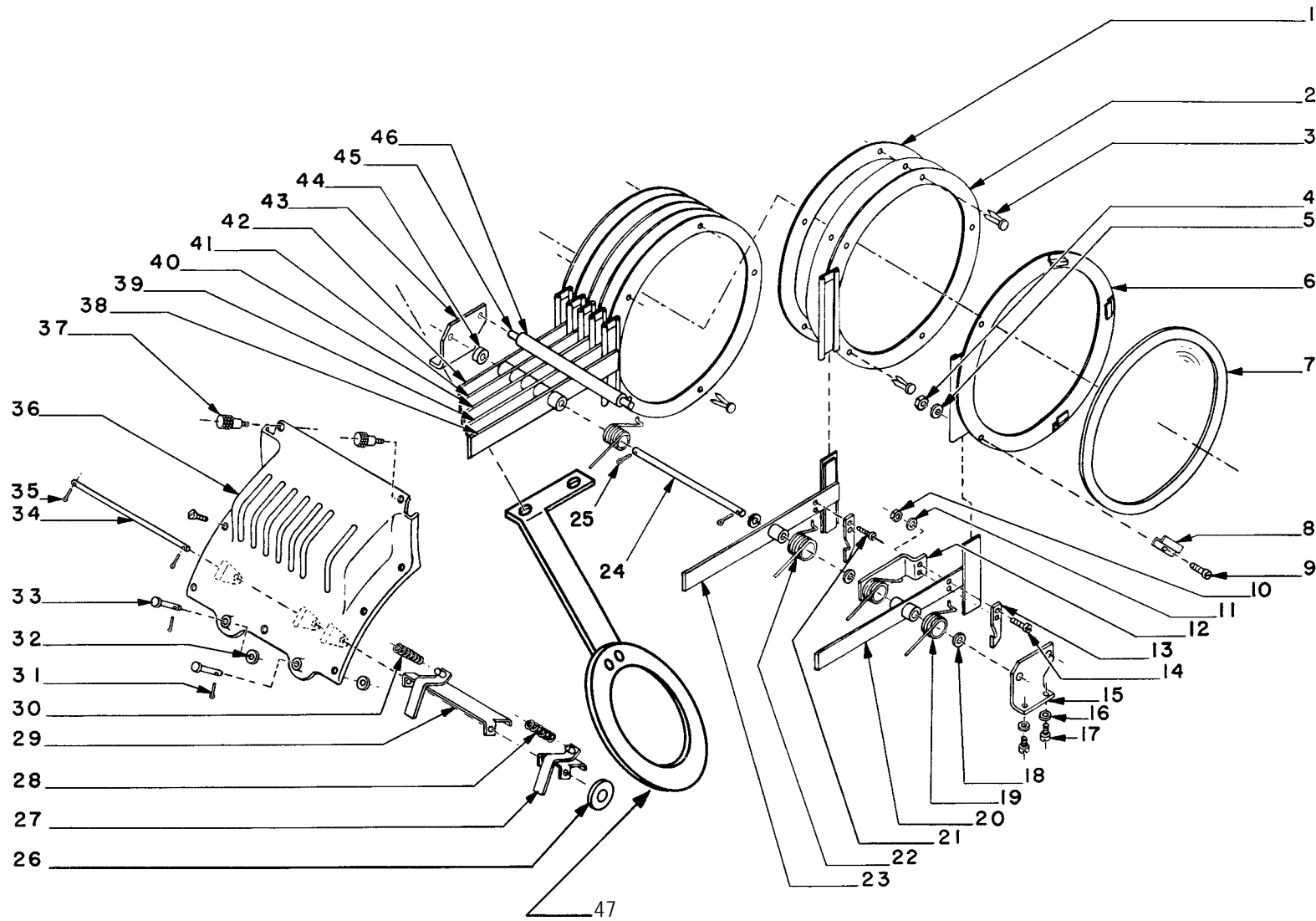

FIGURE 10

PARTS LIST

Figure 10

<u>Item</u>	<u>Part No.</u>	<u>Description</u>
1	51376	Cover Plate, Gel Frame
2	51928	Gel Frame & Slide Channel
3	01456	Paper Fastener
4	00793	Hexnut, 6-32
5	00892	Lockwasher, #8
6	51926	Plate & Slide Channel, Ultra Violet
7	51192	Ultra Violet Lens
8	51406	Clip, UV Lens
9	00180	Screw, 6-32 x 5/16" Fillister Head
10	00795	Hexnut, 8-32
11	00886	Lockwasher, #8 Split Ring
12	51404	Support Arm
13	51396	Catch, Color Arm
14	00220	Screw, 8-32 x 1/2" Round Head
15	51379	Mounting Bracket, Right
16	00894	Lockwasher, #10 Split Ring
17	00315	Screw, 10-24 x 1/2" Round Head
18	51398	Nylon Washer
19	51402	Torsion Spring, UV Filter
20	51927	UV Arm Assembly
21	00255	Screw, 8-32 x 5/16" Fillister Head
-	00886	Lockwasher, #8 Split Ring
22	51465	Torsion Spring, Color Arm
23	51929	Color Arm Assembly, 6-11/16"
24	51403	Pivot Shaft, Color Arms
25	00919	Cotter Pin, 1/16" x 1/2"
26	00866	Flatwasher, #10 S.A.E.
27	51922	Rocker Catch Assembly, Short
-	51506	Rubber Pad, Short
28	17219	Compression Spring, Release Button
29	51923	Rocker Catch Assembly, Long
-	51505	Rubber Pad, Long
30	90473	Compression Spring, Release Button
31	00919	Cotter Pin, 1/16" x 1/2"
32	51467	Washer, Color Release Button
33	51397	Color Release Button
34	51395	Rocker Catch Shaft

PARTS LIST, Figure 10 (continued)

<u>Item</u>	<u>Part No.</u>	<u>Description</u>
35	01475	Cotter Pin, 1/16" x 3/8"
36	51356	Cover, Boomerang Housing
-	00277	Screw, 8-32 x 1/2" Oval Head
37	51166	Retaining Screw, Boomerang Cover
38	51930	Color Arm Assembly, 6-3/16"
39	51931	Color Arm Assembly, 5-11/16"
40	51932	Color Arm Assembly, 5-3/16"
41	51933	Color Arm Assembly, 4-11/16"
42	51934	Color Arm Assembly, 4-3/16"
43	51378	Mounting Bracket, Left
44	51399	Spacer
45	51400	Stop Shaft
46	51401	Rubber Stop
47	19893	Boomerang Heat Filter Assembly
-	47231	Bracket
-	47232	Heat Filter Mounting Disc
-	47233	Heat Filter
-	46150	Assembly Clip

PARTS NOT SHOWN

51913	Boomerang Housing & Hinge
51471	Rubber Bumper Pad, 7" x 8"
01304	Screw, 8-32 x 5/16" Pan Head
00795	Hexnut, 8-32
00891A	Lockwasher, #8
51355	Boomerang Housing Support Casting, Rear
00275	Screw, 8-32 x 3/8" Oval Head
51864	Auxiliary Color Holder (replaces UV Filter)

NOTE: Color temperature reduction filters, required for use with television and videotape, are available from theatrical supply dealers.

